

with Installation Instructions

Owner's Manual

Banks Brake[®]

Exhaust Brake System

**1999-2003 Ford Power Stroke 7.3L
Turbo-Diesel Pickups**

THIS MANUAL IS FOR USE WITH SYSTEM 55202-55207

Gale Banks Engineering
546 Duggan Avenue • Azusa, CA 91702
(626) 969-9600 • Fax (626) 334-1743

Product Information & Sales: (888) 635-4565
Customer Support: (888) 839-5600
Installation Support: (888) 839-2700

bankspower.com



Products available from Banks Power for the '99-03 Ford 7.3L



Banks Power Elbow (P/N 48651-48652, 48661-48663)

- Reduces stock outlet and pipe backpressure

Banks Monster® Exhaust System Sport (P/N 48789) **Single and Dual** (P/N 48653-48660, 47391-47399)

- Increases exhaust flow, cuts backpressure, lowers exhaust gas temperatures (EGTs) and increases power.

Banks Ram-Air Intake System (P/N 96885)

- Increases your airflow over stock.
- Adds power, improves fuel economy, lowers EGTs and reduces smoke.

Banks Techni-Cooler® System (P/N 25971-25973)

- Provides increased air flow to the engine by increasing air density for more increased power, lower EGTs and improved fuel economy.

Banks SmartLock (P/N 55266)

- Reduces wear on transmission
- Locks Torque Converter and raises trans-line pressure
- Works with Banks Exhaust Brake

Banks TransCommand (P/N 62570)

- Produces smooth, firm, light-throttle shifts and solid, decisive heavy-load shifts.
- Eliminates excessive clutch slippage

Banks Billet Torque Converter (P/N 72521)

- Higher torque capacity over stock
- Lockup clutch is slip-resistant so transmission fluids stay cooler and transmission life is prolonged.

Banks QuickTurbo (P/N 24456-24457)

- More boost through the powerband
- Does not over-boost
- Turbo-diesel efficiency

Banks Diesel Tuner

Six-Gun (P/N 66513-66515)

Big Hoss (P/N 66505)

- Adds power safely to your vehicle
- Engine and transmission safeguards
- Change power levels on-the-fly

Thermocouple

- Add a temperature limiting function to your Diesel Tuner

OttoMind Programmer

(P/N 66064)

- Contains Banks tunes that boost your vehicles HP, Torque and MPG.
- Displays a host of critical engine functions
- Provides "service technician" diagnostic capabilities
- Has upgradeable functionality, so it will never be out of date

Banks Git-Kit Systems

(P/N 47401, 47511-47514)

Contains:

- Monster Exhaust
- Big Hoss Module

Banks Stinger Systems

Contains:

- Ram-Air Intake Filter
- Monster Exhaust
- Big Hoss Module
- Big Head Wastegate Actuator

Banks PowerPack Systems

Contains:

- Ram-Air Intake Filter
- Monster Exhaust
- Quick-Turbo
- TransCommand
- Techni-Cooler System
- Big Head Wastegate Actuator

Banks Six-Gun Bundle

(P/N 46594-46613)

Contains:

- Ram-Air Intake Filter
- Monster Exhaust
- Six-Gun Tuner
- TransCommand
- Big Head Wastegate Actuator

Banks Big Hoss Bundle

(P/N 46623-46643)

Contains:

- Ram-Air Intake Filter
- Monster Exhaust
- Six-Gun Tuner
- TransCommand
- Big Head Wastegate Actuator
- Techni-Cooler System
- Big Hoss Module
- Power Elbow

Banks Power Combo 1

Contains:

- Big Hoss Module
- TransCommand
- Big Head Wastegate Actuator

Banks Power Combo 2

Contains:

- Six-Gun Tuner
- TransCommand
- Big Head Wastegate Actuator

Banks Power Combo 3

Contains:

- Big Hoss Module
- Monster Exhaust

Banks Power Combo 4

Contains:

- Big Hoss Module
- TransCommand
- Big Head Wastegate Actuator
- Six-Gun Tuner

**For More Information please call (800) 438-7693
or Visit us online @ www.bankspower.com**

General Installation Practices

Dear Customer,

Your new Banks Brake is a uniquely designed exhaust brake with electronic controls, designed to achieve the optimum level of braking from your vehicle's engine.

If you have any questions concerning the installation of the Banks Brake, please call our Technical Service Hotline at

(888) 839-2700 between 7:00 am and 5:00 pm (PT). If you have any questions relating to shipping or billing, please contact our Customer Service Department at (888) 839-5600.

Thank you.

1. For ease of installation of your Banks Brake, please read this 24-page Owner's Manual before starting any work. Become thoroughly familiar with all components and phases of the installation before beginning any work.
2. Inspect all components supplied for any foreign material that may have entered during shipping and handling.

3. Pay particular attention to the routing of wires and hoses. Keep them away from exhaust heat, moving parts and sharp edges that may cause cuts or other damage. Route or tie away from critical areas as required. Keep all wires a minimum of 6" from hot exhaust parts, 8" or more is recommended whenever possible.

WARNING! Never work under any vehicle supported only by a jack of any kind. DO NOT USE concrete blocks or other masonry items that may collapse under the vehicle weight.

NOTE: Prior to beginning any work, please verify the build date of your vehicle.

Systems 55203 and 55206 are for use on 1999 model year vehicles (built prior to 01/99). Systems 55205 and 55207 are for use on 1999½ to 2003 vehicles (built 01/99 or later). The build date of your vehicle appears in the upper left-hand corner of the information sticker located on the driver's side doorjamb. Certain steps in this manual are model-year specific, so be sure to read each step carefully before performing any work.

Installation Procedure

Brake Installation:

1. As a precaution, disconnect the ground of the battery (if there is more than one battery, disconnect both).
2. On the passenger side of the vehicle, temporarily remove the manifold absolute pressure (MAP) sensor (**Figure 8**) from its mounting location by removing the three nuts from the mounting studs. Save the nuts for reinstallation later. Set the MAP sensor out of the way by resting it in the intake valley of the engine.
3. Remove both driver- and passenger-side boost tubes and the intake plenum from the vehicle to allow access to the rear of the turbocharger.

NOTE: Steps 4 through 7 may be skipped if a Banks Stinger, Stinger-Plus or PowerPack is being installed now or is already installed on the vehicle. Refer to the instruction manual for the Banks Power system regarding the modification of the exhaust system, then return to Step 8 of these instructions.

4. Underneath the vehicle, locate the 2-bolt flange on the forward end of the intermediate pipe or the catalytic converter inlet. Measure forward

from the front side of this flange 24½". Make a mark on the pipe at its centerline as shown in **Figure 1**.

5. Using a reciprocating saw or hacksaw, make a straight cut through the pipe (and heat shield, if equipped) at the location indicated in **Figure 1**.

6. Loosen the V-band clamp at the outlet of the turbo and remove the upper portion of the turbine outlet pipe. Retain the V-band clamp for reuse. *NOTE: If system 55203 or 55206 is being installed, use supplied V-band clamp.*

7. Install the supplied heat shield on the Banks turbine outlet pipe (T.O.P.) using three (3) No. 64 worm-drive clamps. Once the heat shield is in position, tighten the clamps. See **Figure 2**.

8. Disengage the exhaust backpressure control rod by sliding the cover on the end of the rod back toward the turbocharger and pulling the rod downward. This rod is below the turbine housing; it is not the wastegate actuator rod that runs across the top of the turbocharger.

9. Using a prybar or similar tool, bend the mounting bracket of the transmission dipstick tube to allow

Figure 1

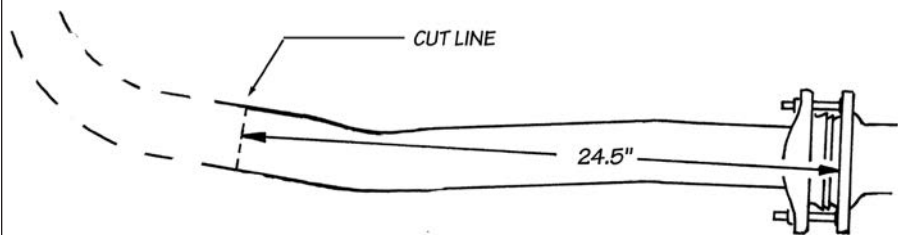
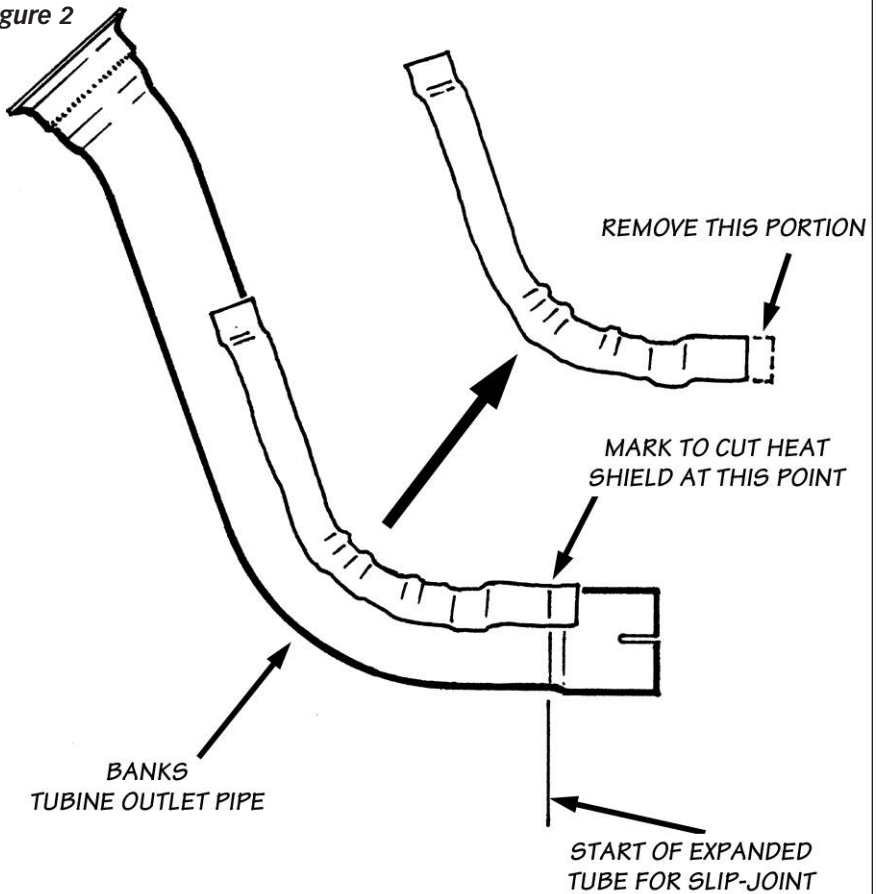

Figure 2



clearance for the Brake housing. See **Figure 3**. The dipstick tube should move toward the turbo about 1" at the bracket and about 6" at the top.

10. Locate the engine lifting hook at the rear of the engine on the passenger side, bolted to the cylinder head. Remove the lifting hook. This will allow clearance for the installation of the Brake. It is not necessary to re-install the hook.

11. Remove the exhaust backpressure control valve assembly from the factory turbine housing by removing the seven (12-point, 8mm head) bolts. Retain these bolts for reuse. *NOTE: If a Banks Stinger-Plus or PowerPack is being installed, it is easier to complete this step after the turbocharger has been removed to accommodate the installation of the Quick-Turbo housing. When the turbocharger has been reinstalled in the vehicle, continue with **step 11** in these instructions.*

Figure 3

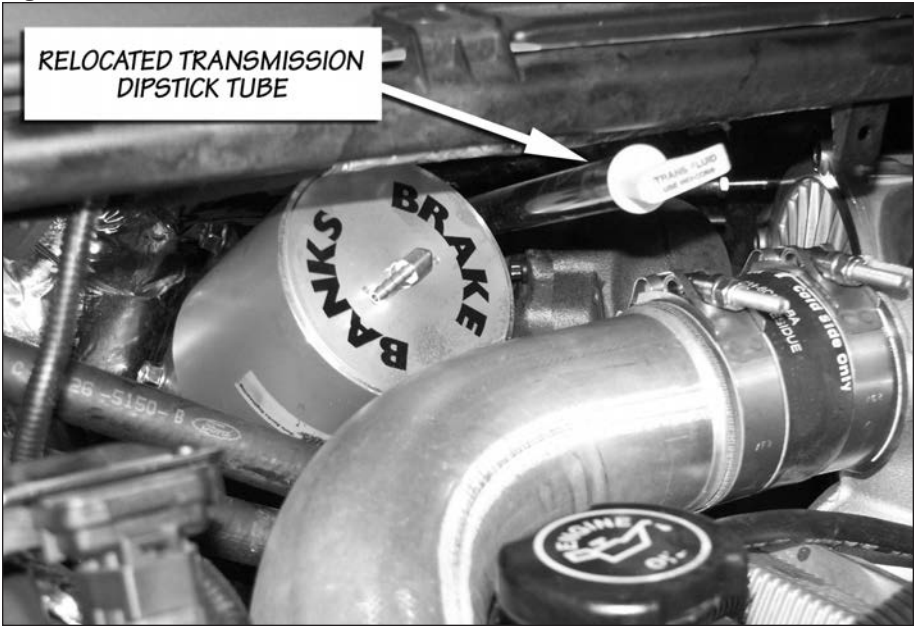

Figure 4

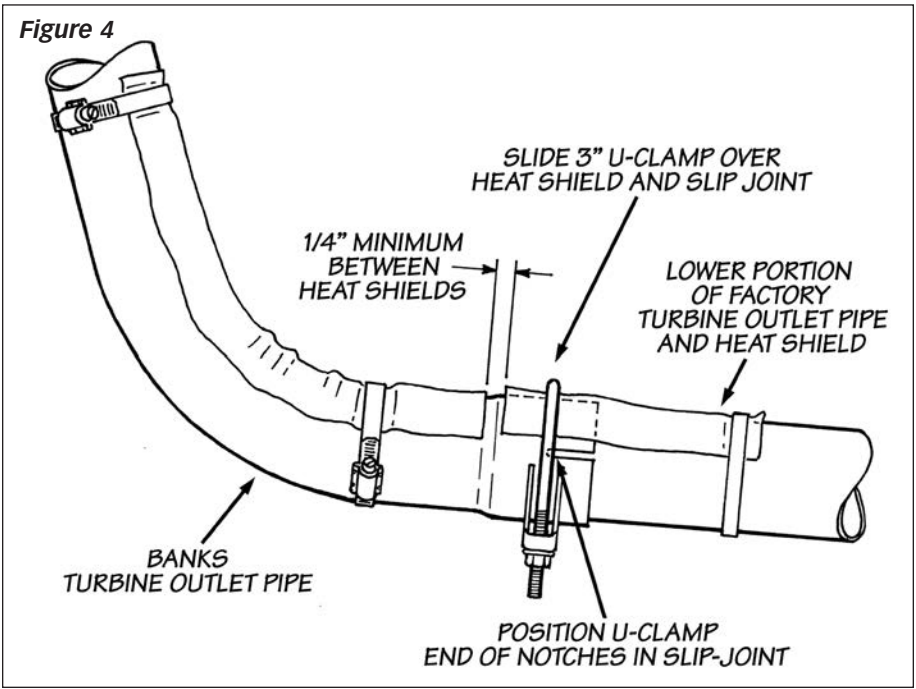
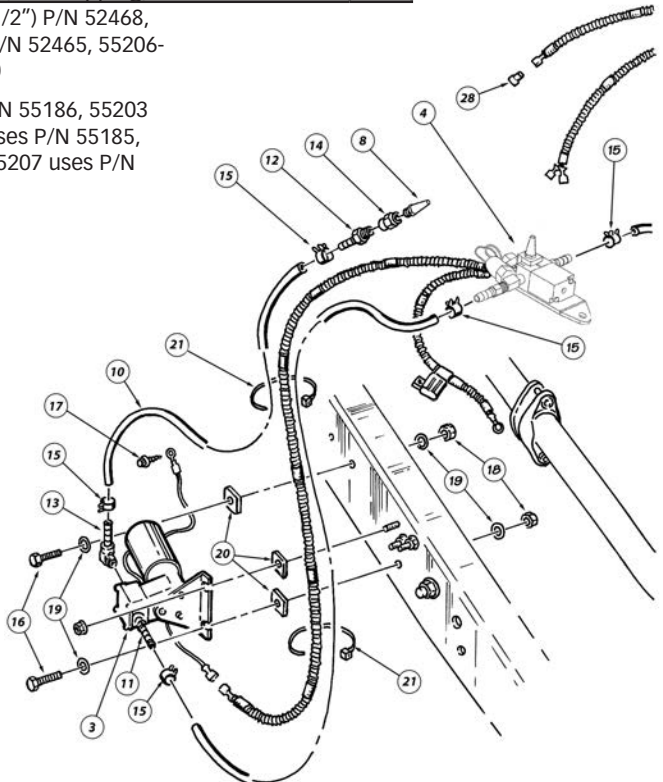

Figure 5

Item #	Part #	Description	QTY
1	55002	Exhaust Brake Assembly	1
2	**	Turbine Outlet Pipe	1
3	55118	Vacuum Pump Assembly	1
4	55115	Actuator Control Valve Assembly	1
5	62130	Switch	1
6	62131	Cover Plate	1
7	55109	Wire Harness	1
8	55170	Bronze Porous Filter	1
9	94121	Silicone Hose, Blue 1/4"	8
10	94128	Vacuum Hose, 7/32"	7 </td
11	92120	Fitting, 1/8" NPT X 3/16" Hose Straight	1
12	92120	Fitting, 1/8" NPT X 3/16" Hose Straight	1
13	92121	Fitting, 1/8" NPT X 3/16" Hose, 90°	1
14	92290	Coupler, 1/8" NPT	1
15	92875	Spring Band Clamp 3/8"	6
16	91229	Bolt, 5/16"-18 x 1"	3
17	91132	Screw, Self-tapping, 1/4-20 x 1/2"	1

* 55202 & 55204 use (3-1/2") P/N 52468,
 55203 & 55205 use (3") P/N 52465, 55206-
 55207 use (4") P/N 52470

** 55202 & 55204 use P/N 55186, 55203
 uses P/N 55184, 55205 uses P/N 55185,
 55206 uses P/N 55210, 55207 uses P/N
 55211



Item #	Part #	Description	QTY
18	91210	Nylock Nut, 5/16"-18	3
19	91202	Washer, 5/16" SAE	5
20	25922	Rubber Mounting Pad	3
21	62002	Cable Ties 11"	16
22***	55036	Support Bracket	1
23***	91455	Bolt, 3/8-16 x 3/4"	1
24***	91922	Bolt, M10-1.5 x 20mm	1
25	55155	Computerized Brake Controller (CBC)	1
26	62062	Fuse, 2-amp	1
27	62029	T-Tap, Yellow	1
28	62034	T-Tap, Red	3
29	62545	Warm-Up Valve Module	1
30	*	Exhaust Clamp	1
	26002	Blanket, Heatshield	1

***Used in Systems 55204 or 55205 only

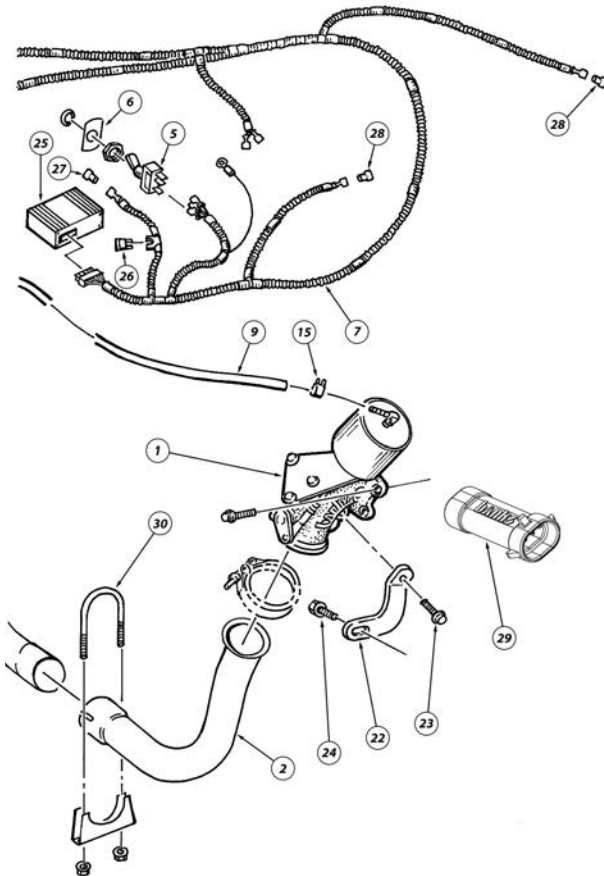

12. Install the supplied turbine outlet pipe onto the front intermediate pipe. Slide a U-clamp over the slip-joint on the Banks turbine outlet pipe. On models 2001 and newer, with a remaining portion of the heat shield on the lower section of turbine outlet pipe, install the U-clamp so that the heat shield is captured under the “U” portion of the clamp when the clamp is in place. Position the clamp so it is located over the inner ends of the slots in the slip-joint for proper sealing. See **Figure 4**. Install the nuts finger-tight, do not tighten the clamp at this time.

NOTE: If you have a previously-installed Banks system on your vehicle and the removal of the upper turbine outlet pipe is difficult, due to the crimping of the pipe by the exhaust clamp, cut the lower pipe 3¾” from its forward edge and use Banks coupler kit, p.n. 55214.

13. Install the Banks Brake assembly onto the outlet of the turbocharger using the original bolts. Use the supplied anti-seize compound on the bolts and tighten them evenly. The torque specification for these bolts is 62 In-lb (not ft-lb!). Check that the molded heater hoses will not rub on the Banks Brake actuator cylinder. Clearance may be provided by sliding the heater hose fore and aft slightly in the hose routing brackets on the passenger side valve cover. *On 2003 vehicles only:* It is necessary to rotate the heater valve toward the front of the vehicle until the vacuum port aims towards the valve cover. The valve can be rotated by loosening the hose clamps located on each end of the

valve housing. Once the valve has been rotated, the hoses should be adjusted by moving them rearward in their mounting brackets until the hoses and valve have adequate (more than ¼”) clearance between the actuator.

14. Clamp the turbine outlet pipe onto the outlet of the brake assembly using the original turbine outlet V-band clamp (on systems 55203 or 55206 use supplied V-band in place of original). Locate the build date of your truck on the information sticker inside the driver’s doorjamb. On trucks built in 1999 or later, position the V-band clamp as shown in **Figure 5** to provide room for tightening. On trucks built prior to 1999, this position will interfere with the cylinder head and the clamp must be positioned with the head toward the firewall. Position all the exhaust components in their original positions, and begin to tighten all exhaust clamps, beginning with the V-band clamp and working downstream.

NOTE: If a pyrometer is used, the probe may be installed in the threaded port, located in the side of the Brake casting. Remove the plug and install the probe using the anti-seize provided.

15. *On trucks built in 1999 and later* (see note on page 4), install support bracket using the supplied bolts. The ¾-16 x ¾” bolt is used on the brake housing side of the support bracket. The M10-1.5 x 20mm bolt is used on the cylinder head side of the bracket. See **Figure 6**.

Figure 6

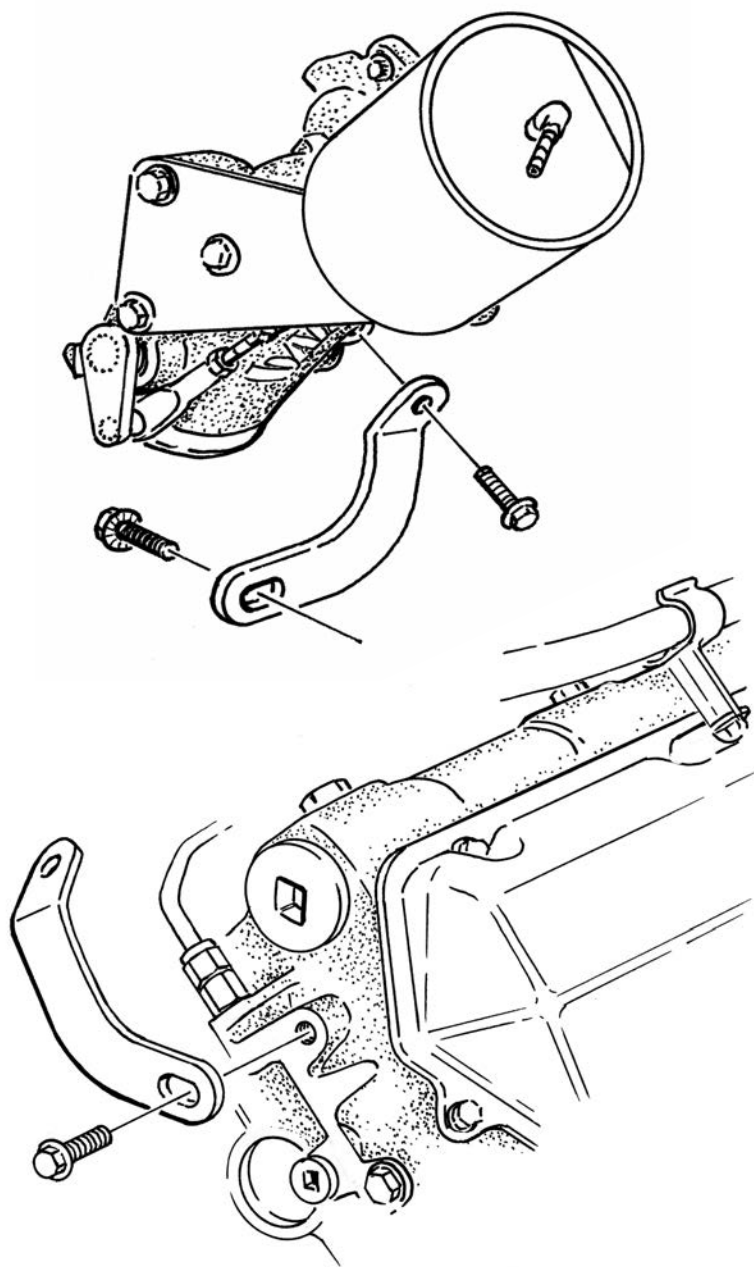

Vacuum Pump Installation:

16. On 1999-2001 vehicles, locate the three exhaust hanger studs protruding through the right side frame rail of the vehicle. The upper rear stud will serve as one mounting point for the vacuum pump. Loosen the nut on the stud and temporarily position the pump with the upper right mounting location under the nut on the stud. The body of the pump should be parallel to the ground. Mark the two other mounting locations to be drilled with a center punch.

Remove the pump. See **Figure 7** for further illustration of the vacuum pump location.

On 2002-03 models, measure $26\frac{7}{8}$ " from back side of body mount to locate two (2) front mounting holes on vacuum pump. Mark the location of the three (3) mounting holes on pump with a center punch.

17. Drill the frame in the previously marked locations, using an $1\frac{1}{32}$ " (.344) drill. Remove any burrs.

18. Install the 90° fitting supplied into the port on the vacuum pump marked "Exhaust". Install the $\frac{1}{4}$ " NPT X $\frac{3}{16}$ " straight hose fitting into the opposite port on the pump. See **Figure 5** for reference.

19. On 1999-2001 models, mount the vacuum pump using two $\frac{5}{16}$ " bolt, washer and nylock nut assemblies, and the single stud location on the vehicle as shown in **Figure 5**.

On 2002-2003 models, mount the vacuum pump using the three supplied $\frac{5}{16}$ " bolt, washer and Nylock nut assemblies. Insert the rubber mounting pads provided between the pump and the frame. Drill a $\frac{7}{32}$ "

hole in the framerail, where ground wire can reach, and carefully thread the $\frac{1}{4}$ "-20 self-tapping screw into the hole, using care to ensure that it threads in straight. Remove the screw and reinstall it with the pump ground wire secured under the head of the screw.

20. Reinstall the intake plenum and boost tubes.

21. Remount the MAP sensor in its original location. Mount the actuator control valve assembly under the nut on the inboard mounting stud with the hose nipples parallel with the MAP sensor bracket as shown in **Figure 8**.

22. Locate RED wire (with ring terminal). Route this wire to the positive terminal on the passenger side battery.

23. Install the ring terminal under the nut on the positive battery terminal.

24. Begin routing the blue silicone vacuum lines by cutting appropriate lengths to connect the straight fitting on the vacuum pump to the actuator control valve, and the actuator control valve to the brake actuator. Connect the black hose provided to the 90° fitting on the pump. Route both hoses away from the pump toward the actuator control valve to the outside of the right frame rail, away from heat and moving parts. Assemble the $\frac{1}{8}$ " Porous Bronze Filter and the $\frac{1}{8}$ " NPT X $\frac{3}{16}$ " straight hose fitting using the $\frac{1}{8}$ " NPT coupler supplied, and insert it into the top end of the black hose. Use the spring band clamps provided at each hose connection. See **Figure 5**. Do not secure the hoses until instructed to do so later.

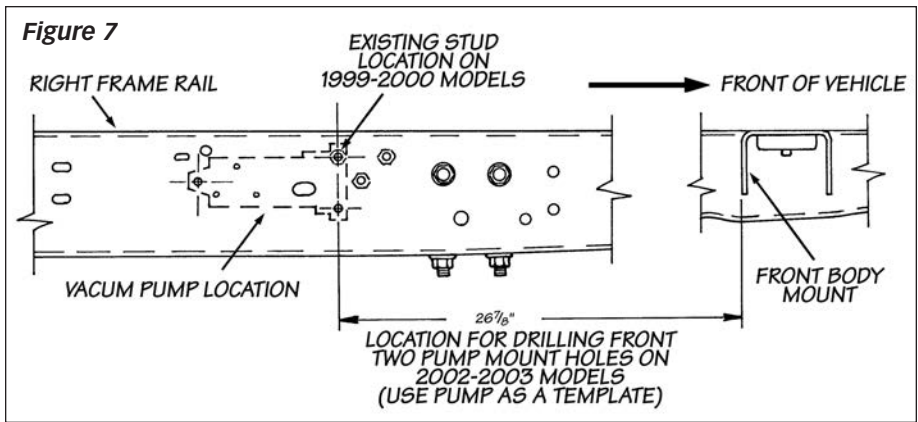
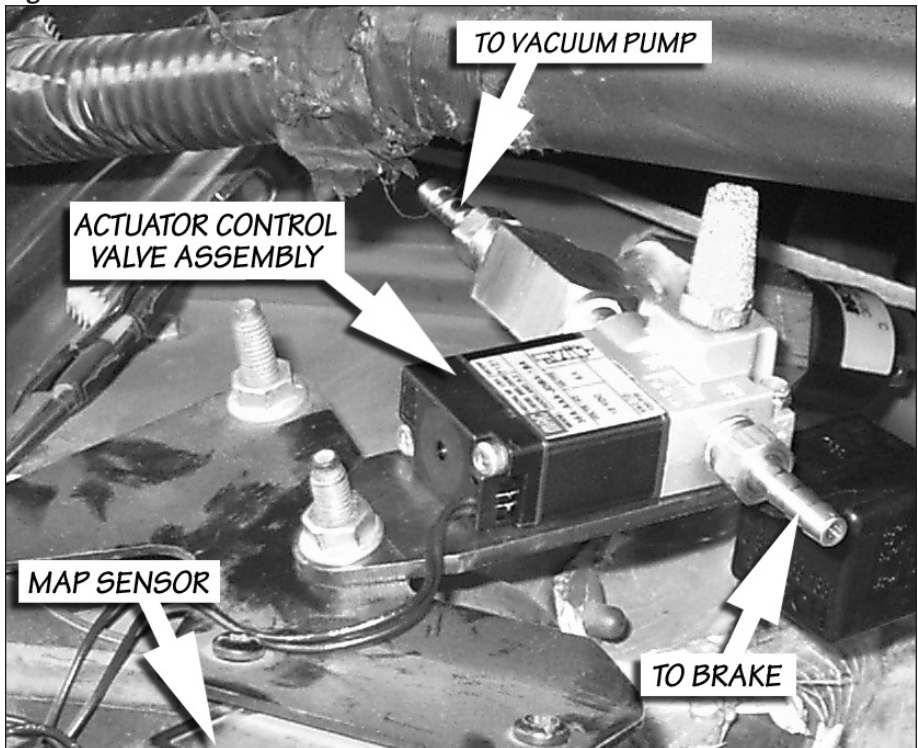

Figure 8



Wiring Installation:

25. Begin by removing the fuse panel cover from the front face of the dash kick panel. This will allow for better visibility of components and access to mounting locations.

26. Remove the template at the back of this booklet (**Template 1**) and cut it out along the dotted lines. Place the template over the dash panel as shown in **Figure 14**. Drill a 1/2" hole through the dash panel at this location.

27. Under the dash, locate the large WHITE wire junction block mounted to the underside of the steering column just to the inside of the dash panel. There are two RED wires with black tracers in this location. Install the supplied yellow T-tap provided in the smaller of the two RED wires. See **Figure 9**.

28. Locate the accelerator pedal position sensor mounted at the top of the throttle pedal assembly. Identify the GRAY wire with a WHITE STRIPE and install the supplied red T-tap provided in this wire. See **Figure 10**.

29. Under the dash, locate the factory ground location on the right hand side of the underdash area. Install the BLACK wire with the ring terminal under the head of the factory bolt. See **Figure 9**.

30. Plug the Computerized Brake Control (CBC) module into the 14 pin connector on the Banks Brake wire harness.

31. Ensure that the surface of the sheet metal structure under the dash is clean and free of oil, grease, and dirt. Clean and dry as required using a cloth dampened with rubbing alcohol or similar cleaning solution.

CAUTION: Do not spray fluid directly onto any electrical equipment, or damage to the equipment may result.

Peel the protective backing off the adhesive tape on the backside of the CBC. Install the CBC onto the sheet metal structure under the dash as shown in **Figure 9**. Hold the module against the vehicle structure for approximately one (1) minute while applying pressure to allow the tape to properly adhere to the structure.

32. Plug the YELLOW wire onto the upper terminal (with respect to the switch plate) on the power switch, the RED wire onto the middle terminal and the remaining BLACK wire onto the lower terminal (see **Figure 11**). Remove the outer locking ring from the shaft of the switch assembly and install the switch from the back side of the dash panel with the notch in the shaft facing down. Slide the face plate provided over the shaft of the switch to indicate switch position. Thread the locking ring onto the shaft of the switch body. The depth of the switch may be changed by adjusting the location of the back nut on the switch shaft.

33. Route the power lead (BLACK wire with male spade terminal and inline fuse) to the YELLOW wire tap previously installed and plug it in. Route the BLUE wire with the male spade connector to the wire tap in the accelerator pedal position sensor and plug it in. See **Figure 9** and **10**.

34. Install supplied 2-amp fuse into inline fuse holder.

35. Locate the heat shield retaining nut and stud on the left side of the engine compartment firewall, near the rear corner of the engine's left valve cover. Remove the nut and gently pull

Figure 9

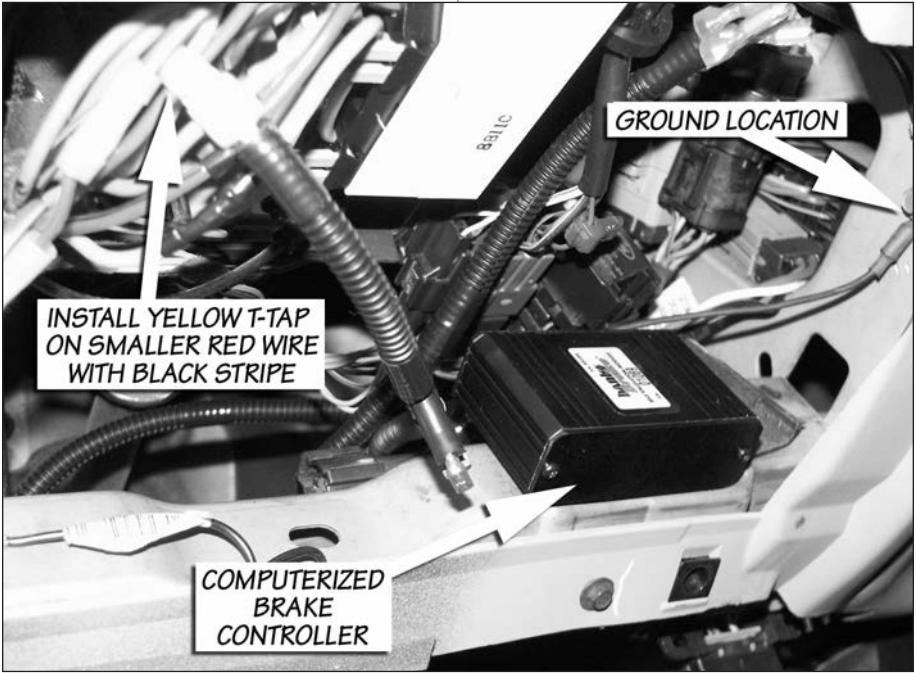

Figure 10

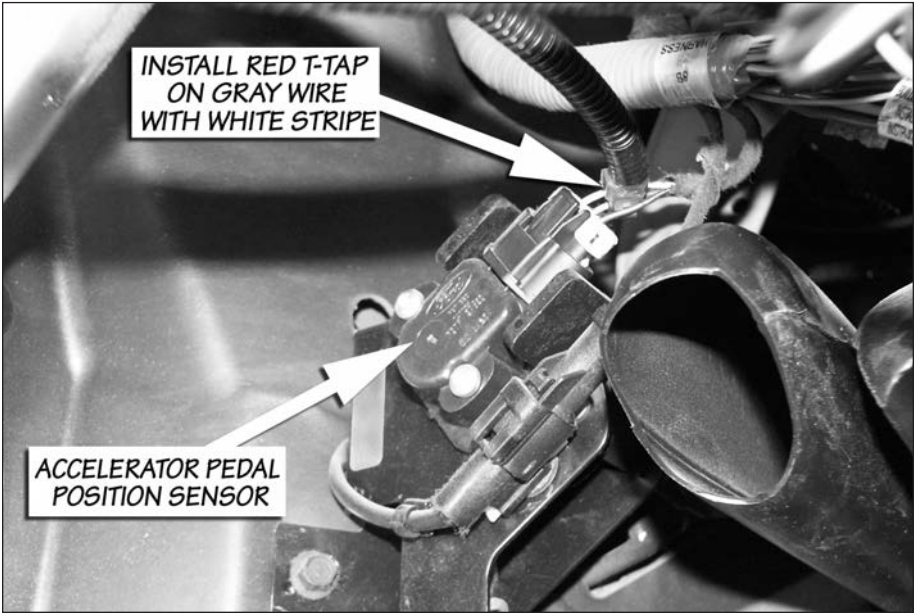
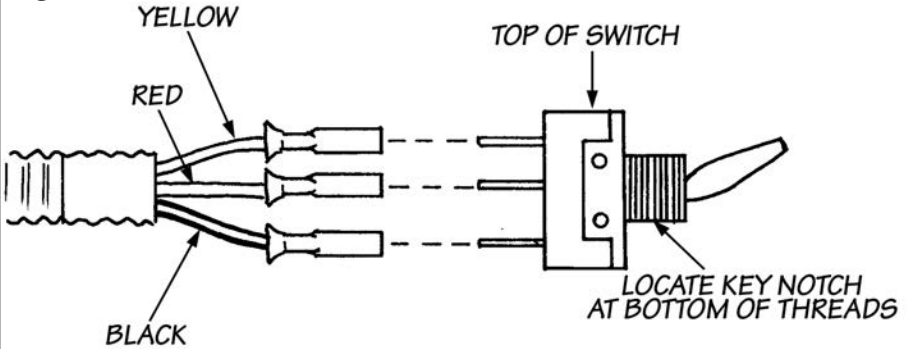

Figure 11



the heat shield away from the firewall to reveal a plastic plug covering a 1/2" hole in the firewall. Remove the plug from the hole. Using a hole saw, file, or die grinder, enlarge the hole to 1" in diameter.

36. From under the dash of the vehicle route the remaining portion of the wire loom through the hole in the firewall. Install the supplied rubber grommet onto the wire harness so that it will protect the harness against damage due to the sharp edges of the firewall sheet metal. In the engine compartment on the driverside close to the fender install the supplied RED T-tap onto the GRAY wire with BLACK STRIPE on the ECU connector (pin 58). Connector can be disconnected from the ECU for easier T-tap installation. See **Figure 17**. Plug the ORANGE Banks Brake wire onto the T-tap.

37. Locate the RED wire with the WHITE STRIPE at the coolant temperature sensor connector (see **Figure 12**). For 2002-03 models, locate the TAN wire with an orange stripe (Note: A RED and WHITE wire may be in close proximity). Install the supplied red T-tap on the wire.

38. Plug the GRAY Banks Brake wire onto the T-tap installed in the previous step.

39. On the end of the brake master cylinder assembly, locate the brake validation switch. See **Figure 13**. Reveal the two wires connected to the switch from the factory sheath and isolate the BLACK wire with YELLOW TRACER. Make a cut in the wire about 2" away from the connector. Strip each end of the wire with a proper wire stripping tool and crimp the male and female spade connectors supplied onto the wire ends with a crimping tool. Route the two BROWN wires from the Banks Brake wire loom toward this location and mate the connectors.

40. Route the remaining leads along the underside of the cowl lip, toward the previously mounted actuator control valve assembly. Connect the BLACK and GREEN wires from the harness to the BLACK and GREEN wires on the actuator control valve assembly.

41. Route the RED wire from the actuator control assembly down toward the vacuum pump along the same path as the vacuum line already installed. Plug the spade connector into the pigtail on the pump.

42. Reattach the heat shield to the firewall with the wire loom and the pump lead protruding out the top of the heat shield.

Figure 12

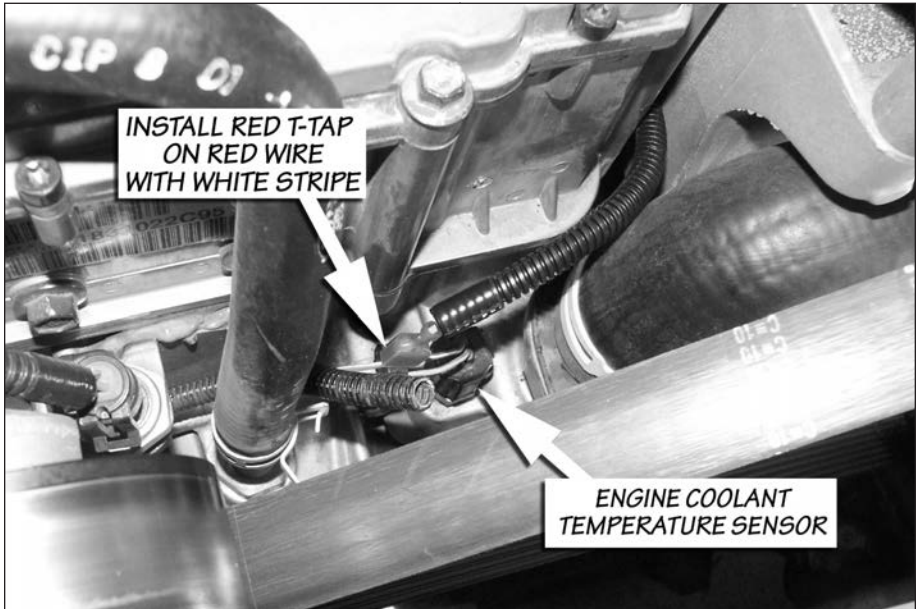

Figure 13

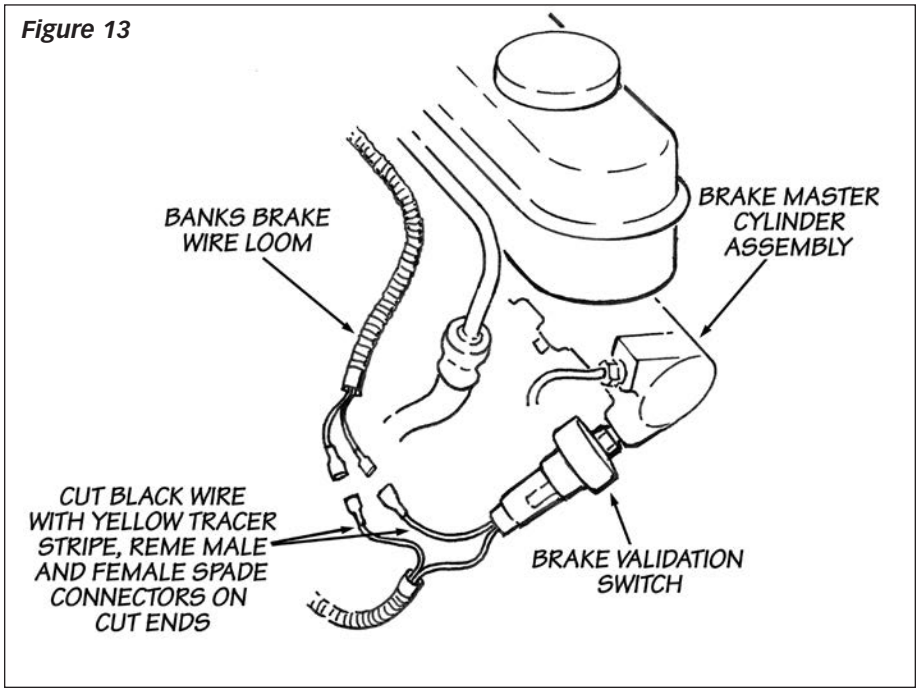

Figure 14

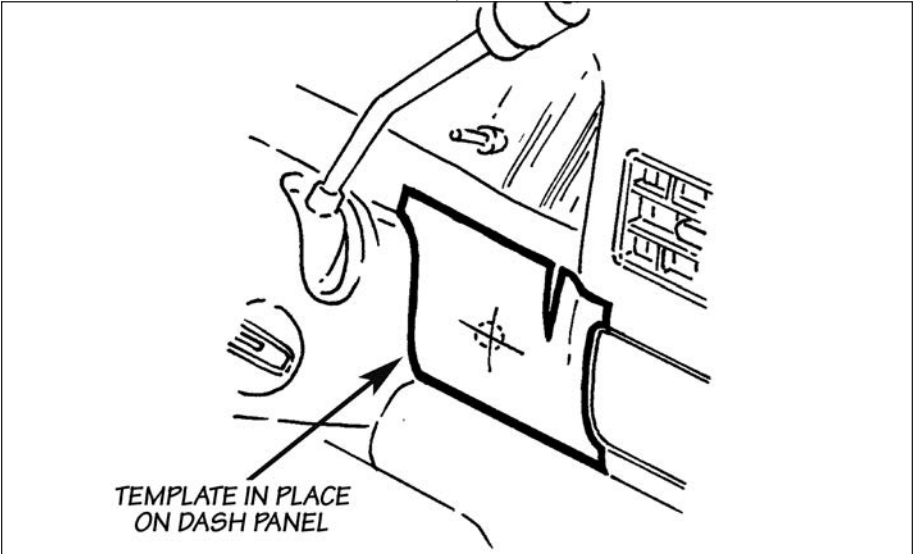
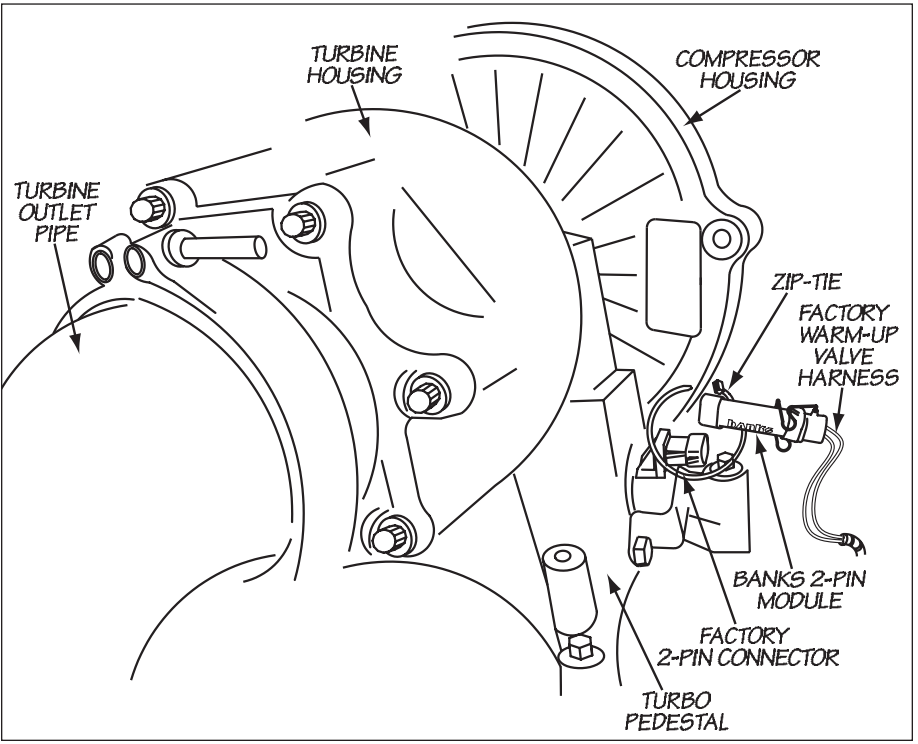

Figure 15



43. Secure the wire loom under the dash and hood using the nylon ties provided. When securing the vacuum pump wire with the vacuum hose, use care to avoid pinching the hoses closed.

44. The 2-pin warm-up valve module needs to be installed onto the warm-up valve connector on the vehicle wire harness. On the pedal stool under the turbocharger, disconnect the 2-pin connector. Attach the 2-pin connector

to the Banks warm-up valve module and zip-tie the module and wire harness away from any moving parts. See **Figure 15**.

45. Your System includes two (2) Banks Power Logos that have been designed to compliment the Ford badging on your truck. We have provided measurements, which will allow you to place these logos in a position that gives a clean factory look. See **Figure 16**.

Figure 16

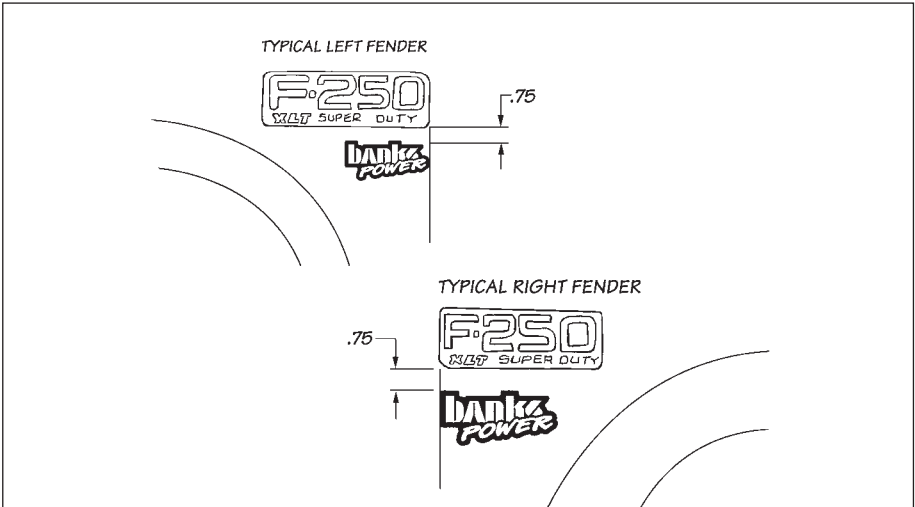
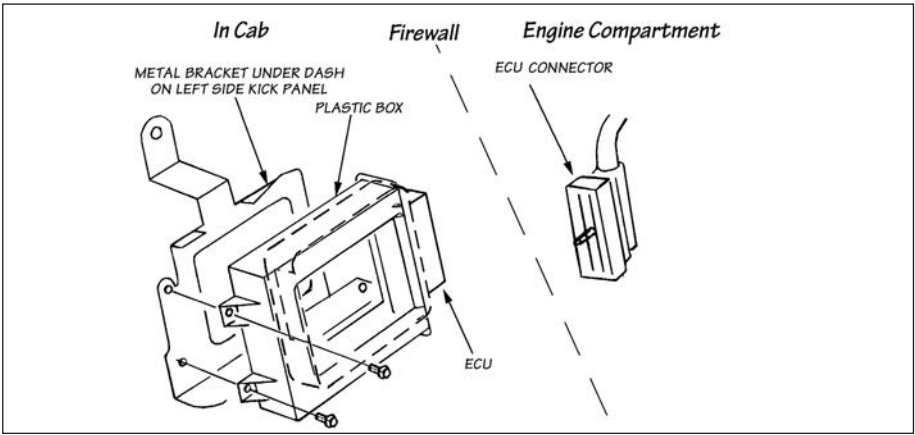

Figure 17



Functional Testing

NOTE: The following testing should be performed only after the vehicle has been allowed to COMPLETELY COOL. This test verifies the performance of the warm-up feature of the brake system and must be performed with a cold vehicle.

46. Verify that the Banks Brake Activation Switch is in the "OFF" position.

47. Ensure that the accelerator pedal is NOT depressed. Turn the ignition key to the "ON" position. The green LED on the Computerized Brake Controller (CBC) should light up and the vacuum pump should run for approximately 2-3 seconds before turning off.

48. Slowly press the accelerator pedal. The green LED should turn off. Release the accelerator pedal and the green LED should again light up and the vacuum pump should run for approximately 2-3 seconds and then shut off. Repeat this cycle a few times to verify CBC function.

49. Start the engine and let it idle. The brake valve will close and can be verified by the muffled sound of a restricted exhaust pipe.

50. Slowly press the accelerator pedal. The green LED should turn off almost immediately (very little throttle movement) and the solenoid valve assembly should vent the air from the brake actuator and the brake valve should open. Release the accelerator pedal and the green LED should again light up and the vacuum pump should run for approximately 2-3 seconds and then shut off. Repeat this cycle a few times to verify CBC function.

NOTE: The engine speed (RPM) should not exceed 1200 rpm prior to brake disengagement.

51. Allow the vehicle to reach normal operating temperature. The brake will remain active until the vehicle reaches approximately 100°F engine coolant temperature. Once the vehicle warms up, the brake will turn off.

52. Re-install the lower dash panel.

*NOTE: Once the vehicle has passed the initial functional tests outlined in **Steps 45-50** the vehicle can be driven in order to complete the required functional testing.*

53. Obtain a vehicle speed of approximately 40-45 mph in an area where speeds of this nature are safe and traffic is light. Turn the Banks Brake activation switch to the "ON" position. Release the throttle. The brake should activate and the vehicle will begin to slow. Bring the vehicle to a safe stop (using the service brakes). As the vehicle speed drops below approximately 15 mph the brake should turn off. Turn the Banks Brake activation switch to the "OFF" position.

54. Obtain a vehicle speed of approximately 40 mph in an area where speeds of this nature are safe and traffic is light. Set the cruise control to 40 mph. Activate the Banks Brake by placing the activation switch in the "ON" position. The cruise control should disengage and the vehicle should begin to slow.

55. Turn the Banks Brake activation switch to the "OFF" position. Activate the cruise control and set it for approximately 40 mph. Press on the brake pedal. The cruise control should deactivate.

*NOTE: Once the vehicle has passed all of the tests outlined in **Steps 52-54**, the installation of the Banks Brake system is complete and ready for years of reliable service.*

Troubleshooting

If the Banks Brake does not pass the FUNCTIONAL TESTING or ceases to function, re-check all connections per the installation instructions.

Test for the following voltages at the CBC connector:

1st, test the following with the engine cold and the KEY ON and ENGINE OFF:

- BLUE wire 0.4 - 1.0V
- GRAY wire 4 - 5V

2nd, test the following with the KEY ON and ENGINE RUNNING:

- YELLOW wire 12V

If any of these voltages are not present, trace the corresponding wire to the connections at either ends and re-check the connections. If all voltages are present, repeat FUNCTIONAL TESTING. The green LED should be lit, indicating the Brake should now function as described.

If green LED does not light or compressor does not run, call Banks Installation Support for assistance.

Safety

CAUTION: Your Banks Brake is NOT a substitute for the hydraulic brakes on your truck. The device will not correct or compensate for improperly maintained hydraulic brakes. Also please be aware that your Banks Brake is not designed to be used as a parking brake or to bring your vehicle to a complete stop. Your Banks Brake is a supplementary braking system designed to help you slow down or to assist you in maintaining a more constant speed when descending a grade. Remember that this exhaust brake is first and foremost a safety device and it is most efficient when used to prevent, rather than correct a runaway vehicle condition.

The use of a Banks Brake does not increase the load capacity of your vehicle. Gross Combined Weight Rating specifications should always be adhered to. The Banks Brake will allow you to slow your vehicle more effectively within your vehicle's weight specifications.

Operation/Driving Tips

Use your Banks Brake to assist in slowing your vehicle while traveling down grades. To activate the brake, flip the switch to the "ON" position. With the switch on, the brake will be active anytime that your foot is not on the accelerator pedal. Note that cruise control will be cancelled if it is active at the time the Banks Brake is engaged. When alternating between braking activity and acceleration, it is a good practice to allow a minimum of one second to elapse after the brake has been disabled or the throttle is applied before reaching full throttle acceleration. This allows enough time for the brake valve to fully open and eliminates the possibility of excess exhaust back pressure being introduced into the engine.

If your vehicle is equipped with an Automatic transmission, your Banks Brake can be used with the transmission in overdrive or 3rd gear.

NOTE: On some 1999-2000 models, the coast clutch may disengage in overdrive resulting in inadequate braking performance. It is recommended that overdrive be cancelled when using the Banks Brake on these vehicles to increase braking performance.

To increase the overall effectiveness of the Banks Brake you may back shift from overdrive to 3rd thereby increasing engine rpm. (Brake performance will be optimal at 2000 rpm or higher.) Back shifting to 2nd gear with the Brake activated is not recommended due to the fact that the torque converter is unlocked in 2nd and could result in increased transmission temperatures.

If braking while in 2nd or 1st gear is required, it is recommended that the Banks SmartLock™ trans controller be installed to ensure that the torque converter clutch remains locked and that there is adequate transmission line pressure. Use of the SmartLock™ in addition to the Banks Brake™ provides increased braking capability while maintaining the integrity of the vehicle's automatic transmission.

NOTE: On some 1999-2000 models, the torque converter may unlock while in 3rd gear under braking conditions resulting in reduced braking capability. The addition of a Banks SmartLock™ will optimize 3rd-gear braking.

If your vehicle is equipped with a manual transmission you can also down shift to maintain peak retarding force.

Maintenance

When the engine is cold (below 100°F) the exhaust brake will activate to reduce the amount of warm-up time required. Once the vehicle reaches operating temperature the brake will open. This cold start brake activation also serves as a maintenance cycle, which helps prevent soot build-up and keeps the shaft assembly from sticking. This process is automated and eliminates the need for any additional maintenance.

If it becomes necessary to remove the CBC from the vehicle, a by-pass plug has been provided to install in its place. If the CBC is removed without being replaced by the by-pass plug, the cruise control will fail to engage. The CBC should only be removed when the ignition switch is in the "OFF" position.

Template 1

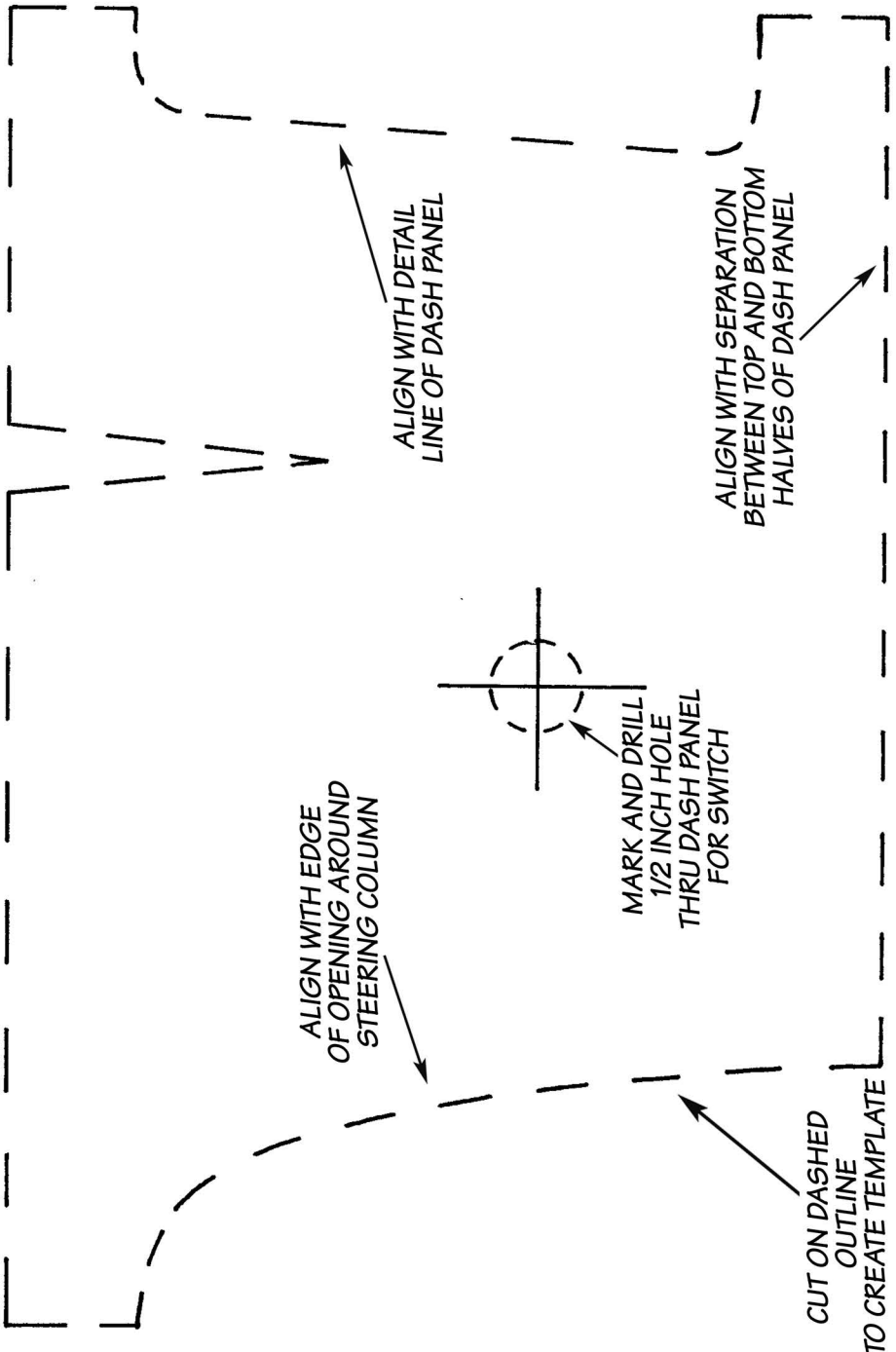

Gale Banks Engineering
546 Duggan Avenue • Azusa, CA 91702
(626) 969-9600 • Fax (626) 334-1743

Product Information & Sales: (888) 635-4565
Customer Support: (888) 839-5600
Installation Support: (888) 839-2700

bankspower.com