

# Owner's Manual with Installation Instructions

## Banks Monster<sup>®</sup> Sport Exhaust System

**2003-2007 Ford Power Stroke 6.0L  
Turbo-Diesel F250/F350 Trucks**

THIS MANUAL IS FOR USE WITH SYSTEMS 48790-48793

Gale Banks Engineering  
546 Duggan Avenue • Azusa, CA 91702  
(626) 969-9600 • Fax (626) 334-1743

Product Information & Sales: (888) 635-4565  
Customer Support: (888) 839-5600  
Installation Support: (888) 839-2700

**bankspower.com**

A large, stylized, grey Banks logo is positioned diagonally in the bottom right corner of the page. The letters are bold and blocky, with a slight shadow effect.

# General Installation Practices

**Dear Customer,**

**If you have any questions concerning the installation of your Banks Power System, please call our Technical Service Hotline at (888) 839-2700 between 7:00 am and 5:00 pm (PT). If you have any questions relating to shipping or billing, please contact our Customer Service Department at (888) 839-5600.**

**Thank you.**

- 1.** Before starting work, familiarize yourself with the installation procedure by reading all of the instructions.
- 2.** The exploded view (**Figure 1**, pages 4-5) provides only general guidance. Refer to each step and section diagram in this manual for proper instruction.
- 3.** Throughout this manual, the left side of the vehicle refers to the driver's side, and the right side to the passenger's side.
- 4.** Disconnect the negative (ground) cable from the battery (or batteries, if there are two) before beginning work.

**5.** Route and tie wires and hoses a minimum of 6" away from exhaust heat, moving parts and sharp edges. Clearance of 8" or more is recommended where possible.

**6.** When raising the vehicle, support it on properly weight-rated safety stands, ramps or a commercial hoist. Follow the manufacturer's safety precautions. Take care to balance the vehicle to prevent it from slipping or falling. When using ramps, be sure the front wheels are centered squarely on the topsides. When raising the front of the vehicle, put the transmission in park (automatic) or reverse (manual), set the parking brake, and block the rear wheels. When raising the back of the vehicle, be sure the vehicle is on level ground and the front wheels are blocked securely.

**Caution! Do not use floor jacks to support the vehicle while working under it. Do not raise the vehicle onto concrete blocks, masonry or any other item not intended specifically for this use.**

**7.** During installation, keep the work area clean. Do not allow anything to be dropped into intake, exhaust, or lubrication system components while performing the installation, as foreign objects will cause immediate engine damage upon start-up.

## **Tools Required:**

- 1/2" and 3/8" drive ratchets with inch and metric sockets and 1/2" and 3/8" drive extension
- Inch and metric combination or open-end wrenches
- Standard screwdriver
- Clean shop towels or rags
- Pry-bar
- Reciprocating saw
- Inch-pound and foot-pound torque wrenches
- Penetrating oil or light lubricant spray
- Transmission jack (manual transmission)

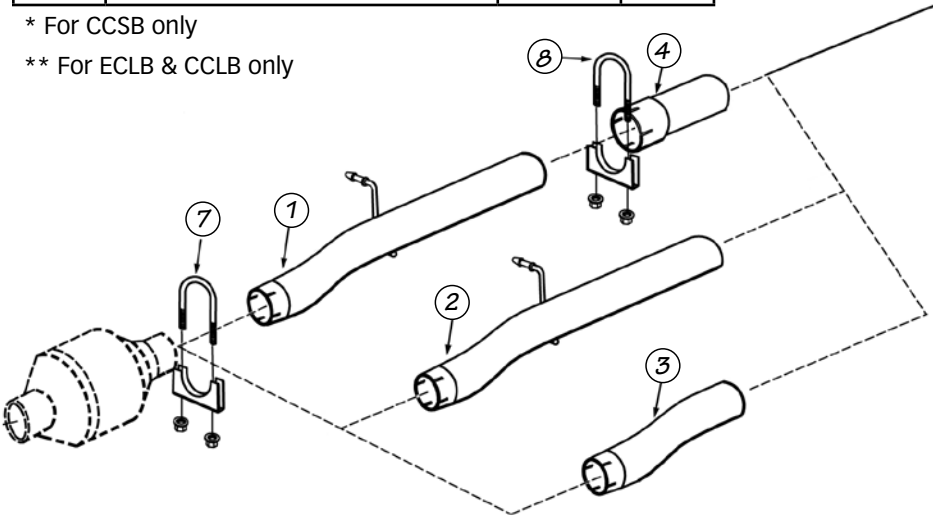
# General Assembly Diagram

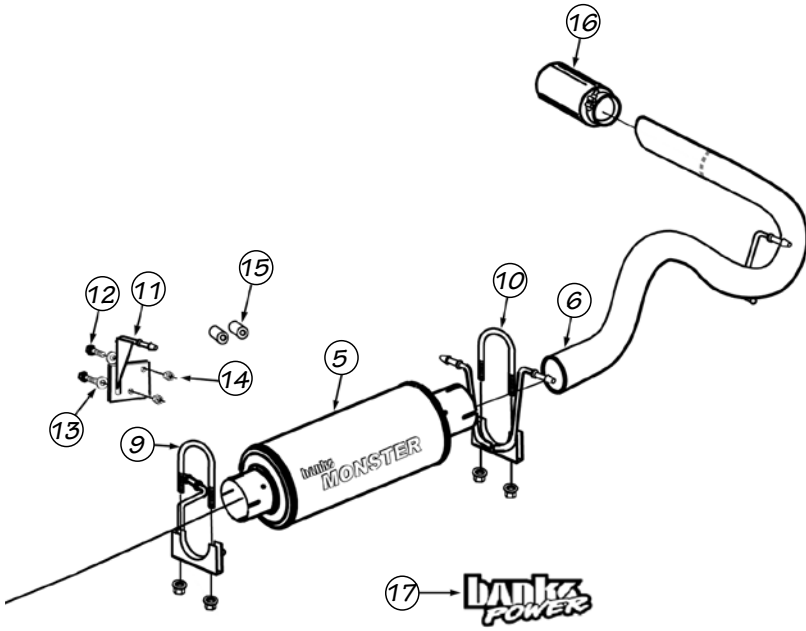
Figure 1

Item	Description	P/N	Qty
1	Intermediate Pipe, CCLB / CCSB	53529	1
2	Intermediate Pipe, ECLB	53530	1
3	Intermediate Pipe, ECSB	53528	1
4	Extension Pipe, CCLB	53531	1
5	Banks Monster Muffler	53810	1
6	Monster Tailpipe	53465	1
7	3 1/2" Exhaust Clamp	52468	1
8	4" Exhaust Clamp, CCLB	52470	1
9	Hanger Clamp, Muffler Front	53453	1
10	Hanger Clamp, Muffler Rear	53454	1
11*	Hanger Pin Assembly	53532	1
12*	Bolt, 8-1.25x30mm	91788	2
13*	Washer, Flat, 5/16"	91202	2
14*	Nut, Lock, 8-1.25mm	91803	2
15**	Spacers, 8mm	91019	2
16	Monster Tailpipe Tip (Optional)	52383	1
17	Banks Power decals	96009	2

\* For CCSB only

\*\* For ECLB & CCLB only





# Monster Exhaust System Installation

**1.** Disconnect the negative (ground) cable from the battery (if there is more than one battery, disconnect both negative cables). Secure the cable so it cannot accidentally come in contact with the post.

**2.** Raise the vehicle and support it securely with properly weight-rated safety stands, ramps or a commercial hoist. Take care to balance the vehicle to prevent it from slipping or falling. When using ramps, be sure the wheels are centered squarely on the topsides. Place the transmission in park (automatic) or reverse (manual), set the parking brake and securely block the wheels that are on the ground.

**CAUTION: Do not work under any vehicle supported only by a jack. Severe injury may result.**

**WARNING! The following step may require the use of a torch and/or saw. Proper safety equipment should be used. Failure to use proper safety equipment may result in severe injury.**

**3.** From under the vehicle, remove the factory exhaust system from the catalytic converter back. Starting at the rear of the vehicle, remove each component by either cutting through the pipe near the clamps or by removing the clamps and heating the joints with an Oxy-Acetylene torch to allow crimped pipes to separate. **DO NOT CUT OR DAMAGE CATALYTIC CONVERTER TUBING DURING THE REMOVAL PROCESS.** Remove the hanger pins from the rubber hangers with a pry bar. (Spray lubricant will ease hanger removal.)

**5.** Place a supplied 3½" clamp onto the front of the supplied intermediate pipe.

**6.** Install the supplied intermediate pipe onto the catalytic converter outlet. Be sure the notch and catalytic converter pin are properly aligned. Lightly snug the 3½" clamp onto the front of the intermediate pipe/catalytic converter outlet.

For *crew-cab long-bed* models, install the supplied extension pipe onto the intermediate pipe and snug a supplied 4" clamp onto the connection.

*Note: Exhaust clamps should be placed at the beginning of the slot and evenly tightened.*

**7.** For *crew-cab long-bed*, *extended-cab short bed*, and *extended-cab long-bed models*, it is necessary to relocate the factory-installed frame-mounted hanger pin that is located behind the rear transmission crossmember.

A) Remove the two (2) factory nuts that mount the front muffler hanger pin to the frame rail and remove the hanger pin from the vehicle.

*Note: **Extended cab short bed models will NOT use the two (2) 3/8" spacers.***

B) Re-install the frame mounted hanger pin using the two (2) 3/8" long steel spacers onto the factory exhaust hanger studs. Install the hanger/spacer assembly into the vehicle frame holes about 10-16" to the rear of the original muffler hanger location (see **Figure 2**).

*Note: Spacers are to be installed between the hanger pin and the inside of the frame rail. Torque factory nuts to 20 ft-lbs.*

**8.** For *crew-cab short-bed models*, it is necessary to replace the factory-installed frame-mounted hanger pin that is located behind the rear transmission crossmember.

A) Using a pry bar, completely remove the rubber hanger from the front muffler hanger pin. Remove the two (2) factory nuts on the front muffler hanger pin from the frame rail and remove the hanger pin from the vehicle. Retain the rubber hanger for re-assembly.

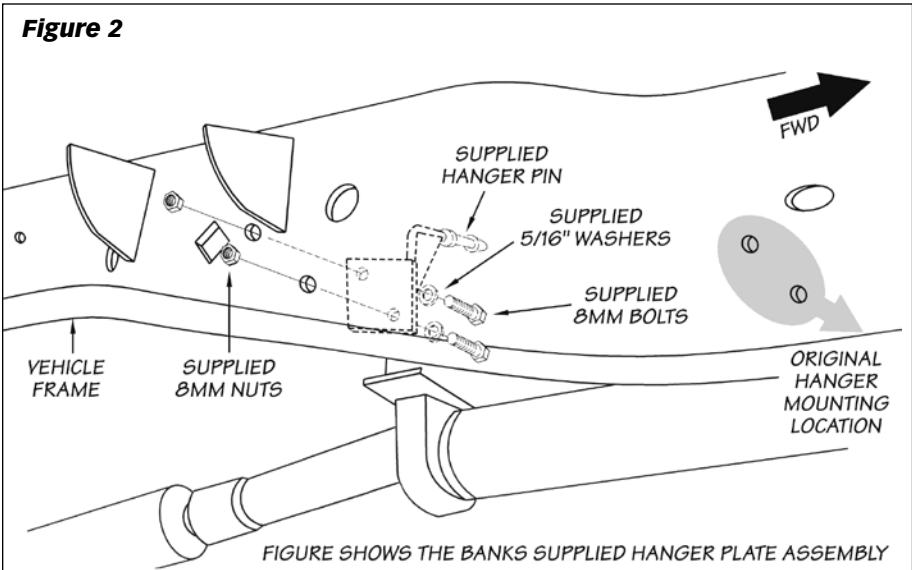
B) Install the supplied hanger pin to the vehicle frame about 10-16" to the rear of the original muffler hanger location (see **Figure 2**). Install the supplied bolts

and washers into the hanger plate and through the frame. Install the supplied nuts and torque to 20 ft-lbs (27 N\*m).

C) Reinstall the rubber hanger onto the mounted hanger pin assembly.

**9.** Install the single pin front hanger clamp onto the rear of the intermediate pipe with the hanger pin on the inside facing the muffler. Insert the hanger pin into the vehicle's rubber grommet. Install the inlet of the Banks Monster muffler to the intermediate pipe.

**10.** Install the dual pin rear hanger clamp onto the outlet of the Monster muffler with the hanger pins on the inside, facing the muffler.



**11.** Route the tailpipe over the rear axle housing and into the muffler outlet. Install the tailpipe hanger pin into the corresponding rubber hanger. Loosely snug the 4" hanger clamp onto the muffler outlet.

**Note:** If installing optional tailpipe tip, cut off 4" from the tailpipe outlet before installing the tailpipe into Banks Monster Muffler. See **Figure 3**.

**If not installing the optional Banks Tailpipe Tip, skip to step 14.**

**12.** Insert the optional tailpipe tip over the tailpipe outlet. Adjust the tip past the edge of the body or where aesthetically pleasing. Torque the band clamp to 35 ft-lb.

**13.** Remove the protective covering from the tailpipe tip.

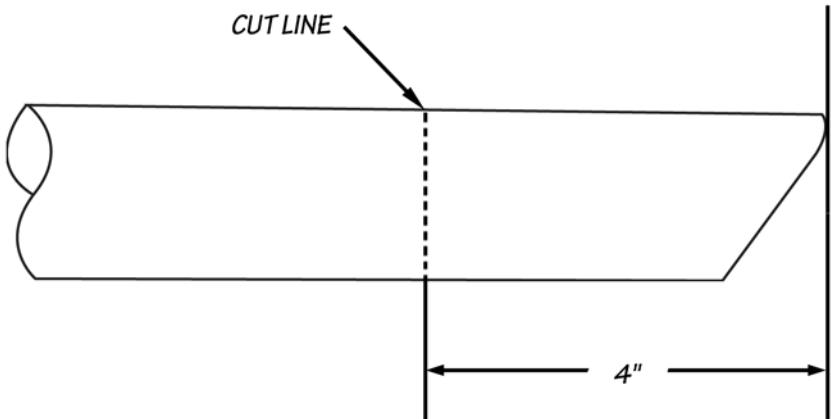
**CAUTION: The protective covering may ignite and burn if not removed prior to running the engine.**

**14.** With everything positioned properly, begin to tighten the clamps starting with the ones closest to the front and working your way back. Torque the exhaust clamps evenly to 35 ft-lbs (47 N\*m). Make sure that each slip is fully inserted (+/- 1/4 inch) and that all mount hangers are in the forward position (see **Figure 4**).

**15.** Your system includes two "Banks Power" logos designed to complement the Ford badging on your truck. Use the provided measurements (see **Figure 5**) to position the logos for a clean factory look.

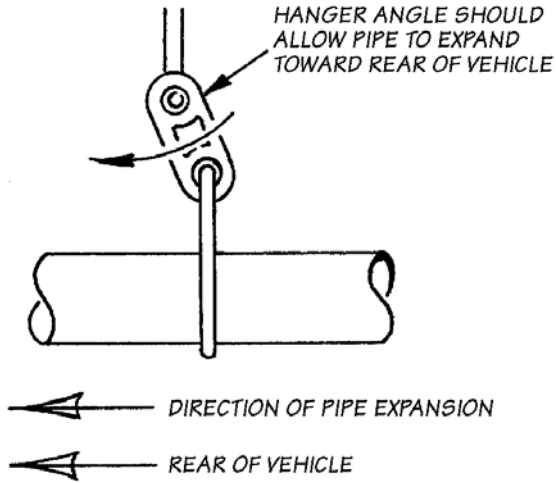
**16.** Re-connect negative battery cable(s). Start the engine and listen for exhaust leaks. Tighten the exhaust clamps as necessary. Whenever possible, tack-welding slip connections to prevent disengagement is recommended. Your Banks Monster Exhaust installation is now complete.

**Figure 3**

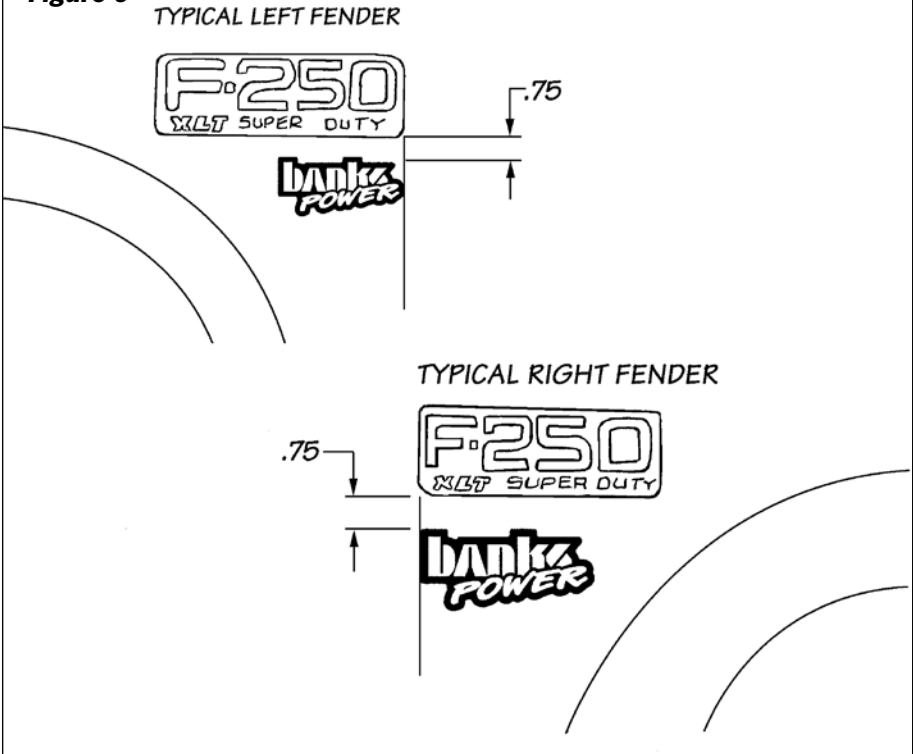




**Figure 4**



**Figure 5**



Gale Banks Engineering  
546 Duggan Avenue • Azusa, CA 91702  
(626) 969-9600 • Fax (626) 334-1743

Product Information & Sales: (888) 635-4565

Customer Support: (888) 839-5600

Installation Support: (888) 839-2700

**bankspower.com**