

OWNERS MANUAL

WITH INSTALLATION
INSTRUCTIONS

banks[®]
POWERPACK

S Y S T E M

INCLUDING STINGER[®]
AND TWINRAM[™] MANIFOLD

banks[®]

GALE BANKS ENGINEERING

546 DUGGAN AVENUE • AZUSA, CA 91702

(626) 969-9600 • FAX (626) 334-1743

www.bankspower.com

This page intentionally left blank.

PREPARATION AND PRECAUTIONS

- 1.** For ease of installation of your Banks system, familiarize yourself with the procedure by reading the entire manual before starting work. This instruction manual contains 20 pages of text, illustrations and parts listing.
- 2.** Throughout this manual, the left-side of the vehicle refers to the driver's side, and the right-side to the passenger's side.
- 3.** This Banks system is designed to fit Class-A Cummins B5.9L powered pusher motorhomes with horsepower ratings of 190, 210 or 230 hp. For further identification check the CPL number on the engine information tag located on the timing cover. This manual applies to CPL's 0987, 1261, 1552 and 1553.
- 4.** Disconnect the ground cable from the battery before beginning work. If there are two batteries, disconnect both.
- 5.** Route and tie wires and hoses a minimum of 6 inches away from exhaust heat, moving parts and sharp edges. Clearance of 8 inches or more is recommended where possible.
- 6.** During installation, keep the work area clean. If foreign debris is transferred to any Banks PowerPack component, clean it thoroughly before installing. Cleanliness is also important on and around the engine. Because diesel pushers tend to gather a large amount of grease and dirt in the engine compartment, steam cleaning or pressure washing the engine prior to the Stinger installation is recommended. Use an engine degreaser on and around the injection pump cover and the injector line fittings.

INSTALLATION PROCEDURE

For TwinRam installation only, proceed to step 51.

TURBOCHARGER REMOVAL

1. Position vehicle on a flat level surface.
2. Disconnect the air inlet tube from the air cleaner and the inlet to the turbocharger. Disconnect the exhaust pipe from the rear of the turbocharger.
3. Remove the two oil drain tube bolts from the turbocharger.
4. Disconnect the oil supply hose at the turbocharger.
5. Note the orientation of the compressor housing in the vehicle. When the new assembly is installed the orientation of the compressor outlet should remain the same. Remove the boost pressure hose from the nipple of the wastegate actuator. Remove the turbocharger mounting nuts and the turbocharger from the exhaust manifold.

CAUTION: Anytime the turbocharger is removed from the engine, take care that no foreign objects enter any of the turbocharger connections on the engine or the turbocharger. Foreign objects entering air, exhaust, or oil connections may cause major damage to the engine and/or turbocharger and is not covered under any warranty. Cover the open end of the intercooler pipe with a rag, as this pipe is very susceptible to foreign object entry.

6. Clean and inspect the exhaust flange mounting surfaces on the exhaust manifold. Remove any remaining gasket material from the turbocharger oil drain flange surface. Make sure the surface is clean and dry.

PYROMETER PROBE INSTALLATION

7. The exhaust gas pyrometer monitors the temperature of the exhaust entering the turbocharger turbine housing. Installation requires that the exhaust manifold be drilled near the outlet of the manifold adjacent to the turbine housing. For this reason it is essential that the turbocharger be removed from the engine in order to clean out any metal chips from drilling that could cause turbine blade damage.
8. The Cummins 6BT engine uses a divided exhaust manifold and turbocharger. The pyrometer probe must be installed to sample exhaust temperature in one of the two exhaust passages. Typically the exhaust temperature will not differ appreciably between the two passages. We recommend installing the probe in the rear manifold passage to simplify routing the probe wiring.
9. Stuff a small shop towel or rag 4 to 5 inches into the rear exhaust manifold passage through the turbocharger mounting flange. This is to prevent chips from entering the manifold while drilling and tapping.
10. Drill through the exhaust manifold into the rear passage at the location shown in Figure 1. Use a $\frac{7}{16}$ -inch drill, keeping the drill perpendicular to the manifold surface.

Figure 1

DRILL AND TAP 1/4 N.P.T. PORT IN ONE PASSAGE OF EXHAUST MANIFOLD OUTLET

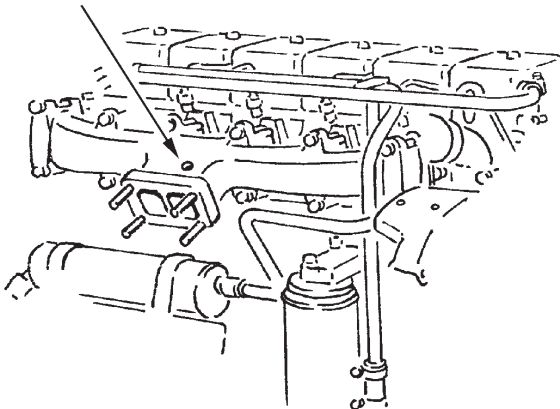

LOCATE PORT 3/4 INCH BEHIND FLANGE, CENTERED OVER RIGHT EXHAUST MANIFOLD PASSAGE, AS VIEWED

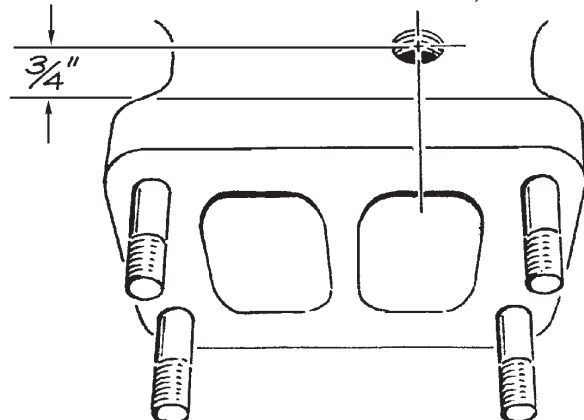

11. Tap the drilled hole with a ¼ NPT pipe tap. Check the thread depth as you tap by periodically removing the tap and screwing the probe fitting (supplied in pyrometer kit) into the tapped hole. The probe should thread in 3 to 3½ turns hand tight. Do not install the probe in place at this time.

12. Remove as many loose chips as possible from the exhaust manifold. A shop vacuum, small brush, or fingers will help. Now remove the rag using a welding rod or coat hanger bent into a hook.

Figure 2

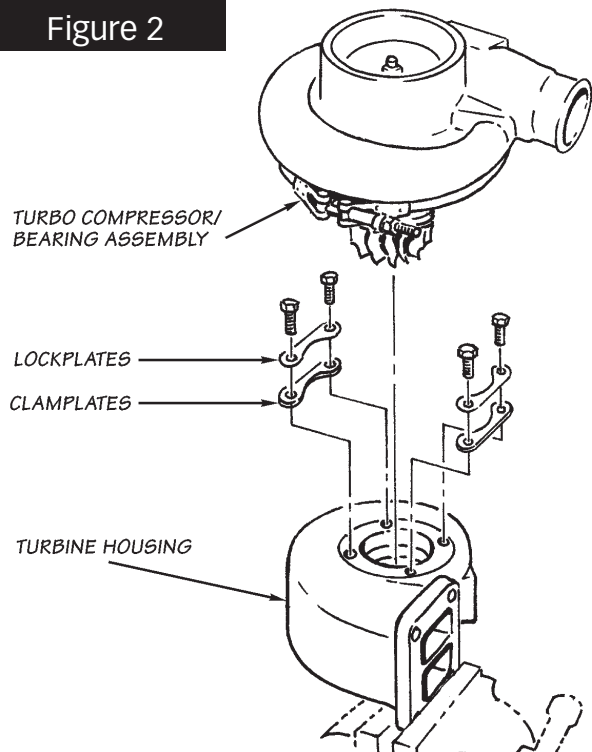

CAUTION! Make sure rags are removed from exhaust manifold prior to reinstalling turbine housing!

13. Install the probe in the manifold. Anti-seize on the threads is recommended.

TURBOCHARGER DISASSEMBLY AND REASSEMBLY:

14. Clamp the turbine inlet flange of the turbocharger in a bench vise. Loosen the four bolts, attaching the turbine housing to the center bearing section of the turbocharger. (See Figure 2)

15. Remove the bolts, lockplates, and clamp plates. Carefully remove the center bearing and compressor assembly from the cast iron turbine housing. If the turbocharger has been in service for some time, rust and carbon may prevent the center bearing and compressor assembly from easily separating from the turbine housing. If light

hammer blows, penetrating oil or heat will not free the compressor assembly from the turbine housing, the clamp bolt adjacent to the turbo oil inlet connection may be backed out so as to push against the bearing casting and separate the two components. Remove any loose rust or carbon from the bearing housing that might prevent proper engagement into the new turbine housing.

16. Install the center bearing and compressor assembly into the new turbine housing supplied. Apply a dab of anti-seize compound to the bolts, then install bolts, clamp plates, and lock plates finger tight to allow for final positioning.

17. Remove the exhaust outlet adapter from the rear of the turbine housing. Clamp the exhaust inlet flange of the new turbine housing in a bench vise. Using the new gasket provided install the turbo exhaust outlet adapter casting to the turbine housing with five 8mm x 20mm metric hex bolts. Apply a dab of anti-seize compound to the bolts, then torque the bolts to 11.3N-m (100 in-lbs.). Make sure the turbine inlet flange does not rotate in the vise while torquing.

TURBOCHARGER INSTALLATION

18. Install a new turbo exhaust inlet gasket provided and apply a dab of anti-seize compound to the four turbo mounting studs. Install the turbocharger on the exhaust manifold. Tighten the turbocharger mounting nuts to 32N-m (24 ft.lbs.) torque.

19. Align the compressor outlet with the intercooler hose adapter and tighten the clamp. Tighten the turbine housing clamp plate bolts to 11.3N-m (100 in-lb.) torque.

20. Spin the turbocharger shaft to make sure it turns freely. If not, loosen the turbine clamp plate bolts and check for misalignment between the turbine housing and turbocharger center section. Retighten bolts and check again.

21. Use the new gasket provided to connect the turbocharger oil drain tube to the turbocharger. Make sure the turbocharger oil drain flange is clean and free of any old gasket material. Tighten the drain flange bolts to 24N-m (18 ft.lbs.) torque. NOTE: If the bolts encounter excessive resistance prior to seating against the flange, check for paint build up in the threads of the turbo bearing housing. The threads may need to be chased with an 8mm x 1.25 metric tap.

22. Reconnect and tighten the turbo oil supply hose.

FIGURE 3

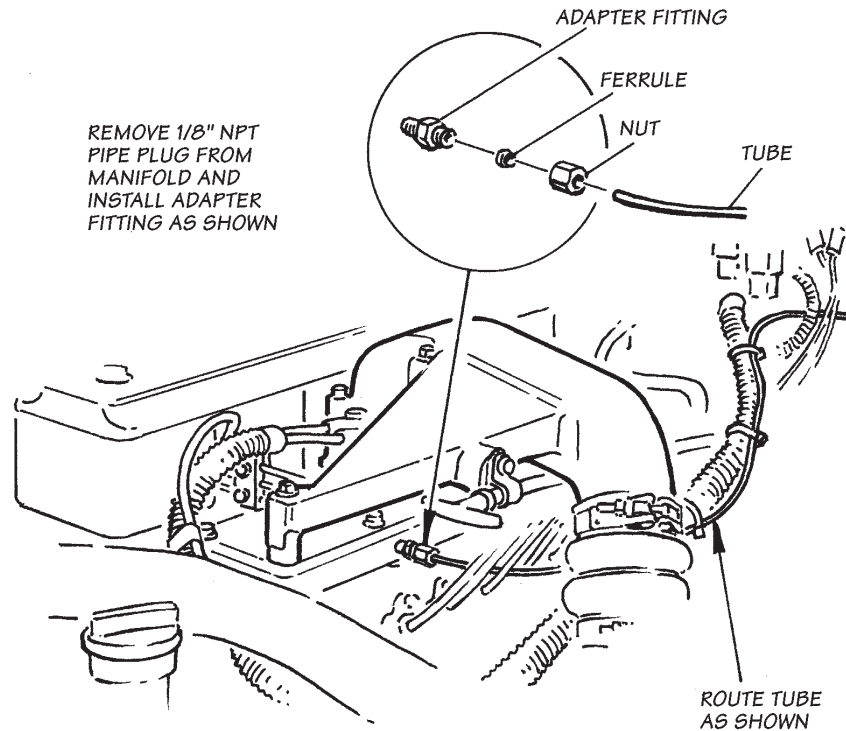

- 23.** Install the air inlet tube (from the air cleaner housing) and the turbo exhaust pipe onto the turbocharger. Reattach the wastegate actuator boost line using a crimp lock clamp provided.

GAUGE INSTALLATION

- 24.** Choose a suitable location under the lower edge of the dash panel for mounting the instrument panel provided where it can be conveniently viewed by the driver.

NOTE: Molded instrument consoles for top-of-dash mounting and additional gauges are available through Gale Banks Engineering.

- 25.** Using the panel as a template, drill two $\frac{3}{16}$ " diameter holes in the dash and mount the panel with two no. 10 x $\frac{1}{2}$ " machine screws, nuts and star washers provided.

- 26.** Locate and remove the $\frac{1}{8}$ " NPT pipe plug on the driver's side of the intake manifold as shown in **Figure 3**. Install the $\frac{1}{8}$ " NPT male x $\frac{1}{8}$ " compression tube adapter at this location. Use Teflon tape or sealant on the pipe thread end of the adapter fitting.

- 27.** Install one end of the $\frac{1}{8}$ " diameter plastic tube provided in the nut and ferrule adapter fitting and tighten the nut. Check that the plastic tube cannot be pulled out of the ferrule, but do not over-tighten the nut.

- 28.** Install the boost gauge in the gauge panel using the clamps and thumb nuts provided. Install the $\frac{1}{8}$ " NPT female x $\frac{1}{8}$ " compression tube adapter fitting onto the connection at the back of the gauge. Use Teflon tape or sealant on the male

threads of the gauge nipple. Use sealant sparingly, and do not allow any sealant to cover the small pin-sized hole in the end of the gauge nipple.

- 29.** Route the plastic tube along one framerail of the coach. Find an opening in the forward bulkhead to route the tube into the driver's compartment. It may be necessary to drill a $\frac{3}{8}$ " hole. Route the tube to the gauge then cut the tube to length. Insert the tube into the nut and ferrule on the adapter fitting at the gauge, then tighten the nut against the tube and ferrule. Do not over-tighten.

- 30.** Uncoil the Pyrometer 4-pin connector gauge harness. As a precaution to improper gauge function, re-crimp the ring terminals on the ends of the wires. Connect the ring terminals to the probe with the supplied screws. Attach the YELLOW & RED ring terminals from the Pyrometer 4-pin connector gauge harness to the Yellow & RED probe ring terminals, Respectively.

- 31.** The wires are different lengths and color coded to prevent cross connecting. Make sure that the screws are tight. Slide the heat shrink tubing over the connections and apply heat to the tubing with a heat gun or other heat source.

- 32.** Route the gauge harness along the same path as the boost hose. Coil any excess length and secure it with tie wraps. **DO NOT cut the harness to shorten it.** The pyrometer is calibrated to operate with the predetermined length provided.

Figure 4

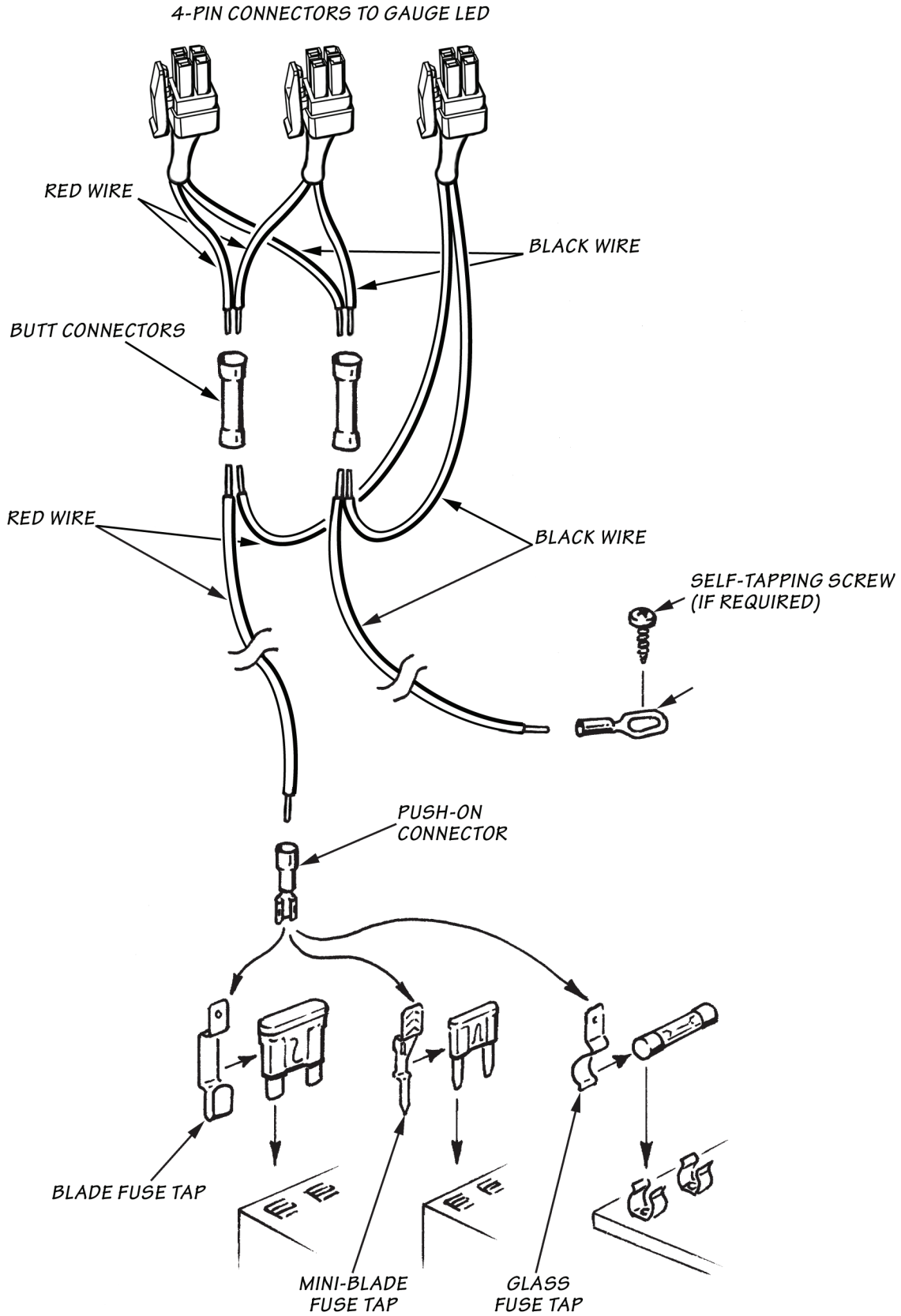
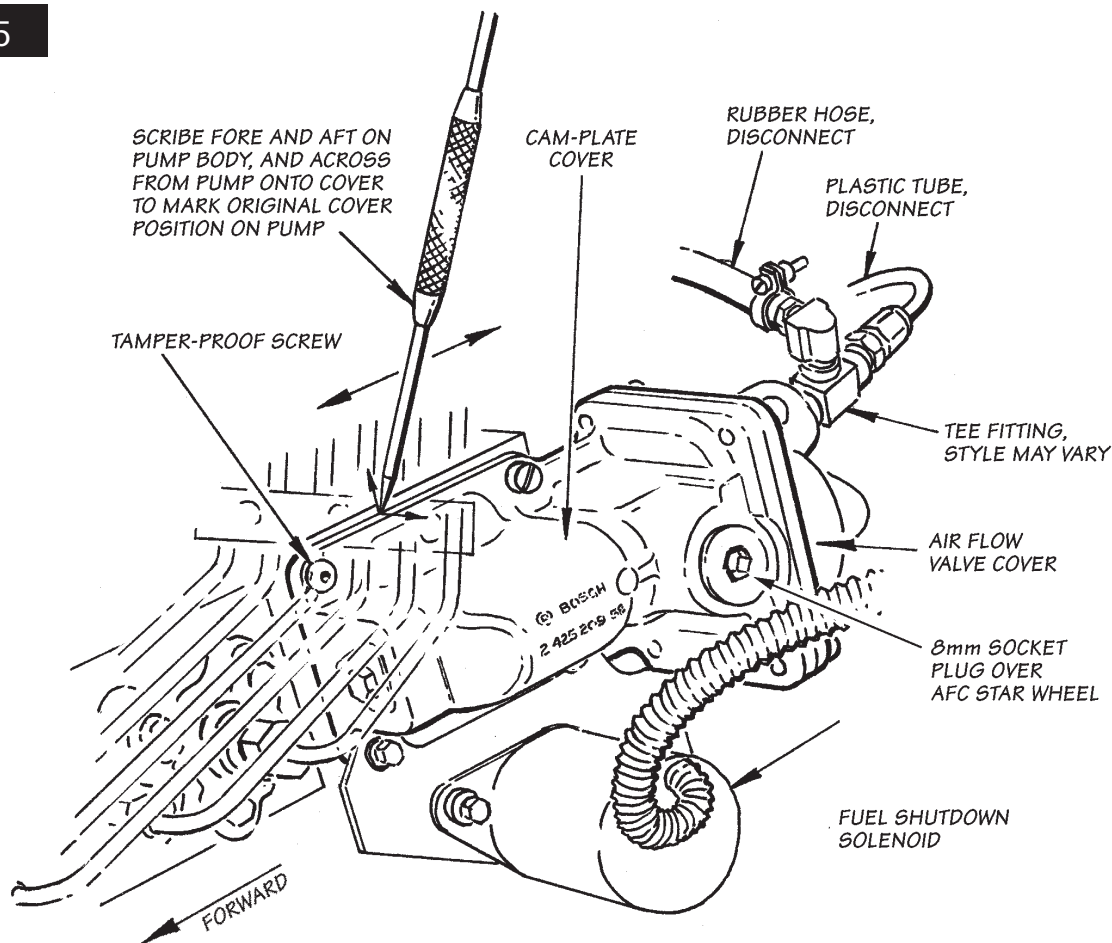

FIGURE 5



GAUGE LIGHTING

33. Connect the 4-pin connector of each gauge into the back of its corresponding gauge.

A. Crimp the remaining BLACK and RED wires from each 4-pin connector gauge harness to the butt connectors as shown in **Figure 4**.

B. Strip one end of the RED wire and crimp it to the butt connector containing the RED wires from step 'A'.

C. Strip one end of the BLACK wire and crimp it to the butt connector containing the BLACK wires from step 'A'.

D. Route the RED wire to the fuse box. Locate the appropriate fuse for instrument lighting in the owner's manual. Cut the RED wire as required and strip the end. Crimp the push on connector to the RED wire and connect to the fuse as shown in **Figure 4**. Alternatively, locate power wire to dimmer switch and install T-tap. Cut the RED wire as required and strip the end. Crimp the push on T-tap connector to the RED wire and connect to T-tap on dimmer power wire.

E. Locate a metal surface that will serve as an acceptable chassis ground. Cut the BLACK wire to a sufficient length that will allow it to reach the chassis ground and strip the end. Crimp the ring

terminal to the Black wire as shown in **Figure 4**.

F. Drill a 1/8" hole, if required, to attach the ring terminal to the chassis ground.

Caution: If drilling, check the backside to make sure there are no components that may be damaged by drilling.

G. Use the supplied self-tapping screw to secure the ring terminal to the chassis ground.

OTTOMIND INSTALLATION

34. To realize power gains made available by the increased airflow through the Banks components, the fuel delivery of the injection pump must also be increased. This procedure will provide the additional fuel flow required. The injection pump is located on the upper left side of the engine, and can be identified by the row of six injector pressure tube connections on top of the pump body.

35. Loosen the upper hose clamp on the boost tube hose joint at the intake manifold inlet casting. Remove the hose from the inlet casting and push out of the way. Cover the intake manifold opening and the open end of the boost tube with clean rags to prevent foreign object entry.

FIGURE 6

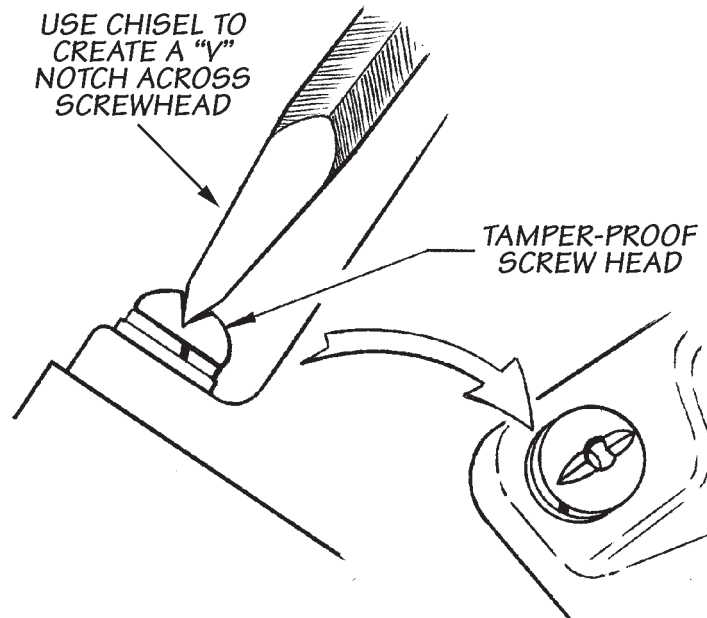
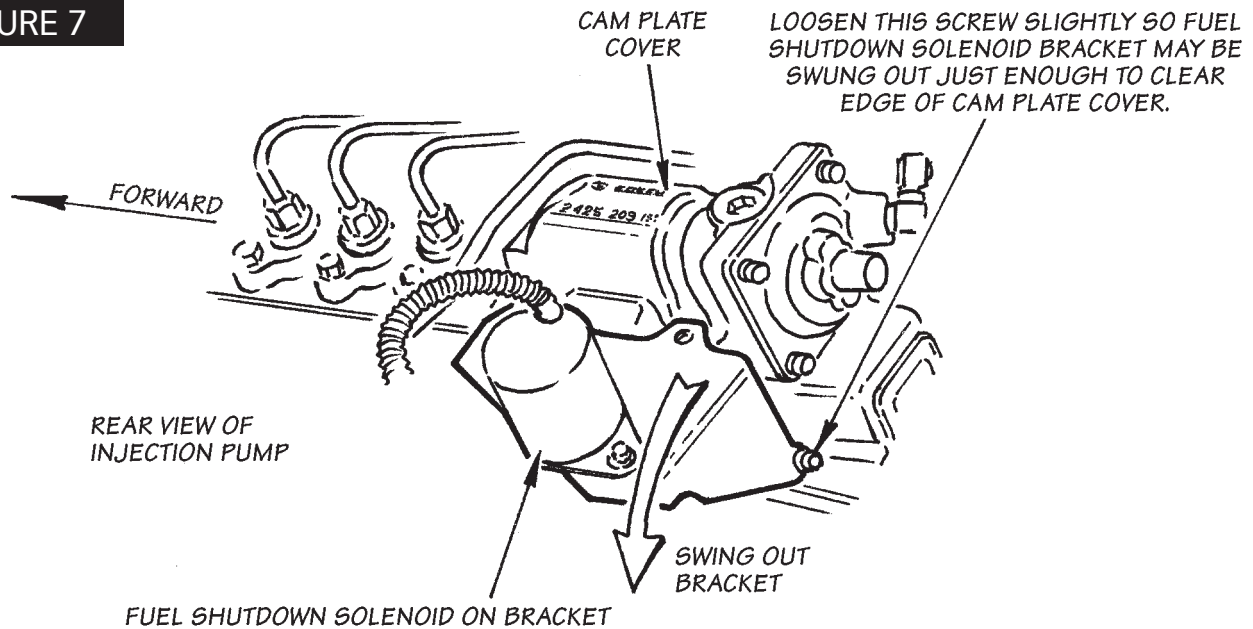

FIGURE 7



36. Locate the cam plate cover on the injection pump. See **Figure 5**. The cover is just to the rear of the area where the six injector pressure tubes connect to the pump body, and is retained by four screws. Clean any dirt, grease, or foreign material from the cam plate cover, especially in the area where the cam plate cover flange contacts the main pump body, to prevent contaminants from entering into the pump upon disassembly.

37. Use a sharp scribe to scribe a line in the injector pump body along the outside edge of the cam plate cover where the cover attaches to the pump (along the upper edge of the cover, on the side facing the engine). Then scribe another line

at a right angle across the first, from the pump body onto the cover. These scribe lines are to enable you to reinstall the cam plate cover in exactly the same position. You may make any additional scribe lines if you feel it may be helpful.

38. Loosen and disconnect a rubber hose and a plastic tube from a "tee" fitting located in the air flow valve cover. This is a smaller cover attached to the rear of the cam plate cover, with four screws facing the rear of the engine.

39. The upper forward screw attaching the cam plate cover to the fuel pump body has a factory break-off tamper proof head. This screw head must be modified to provide some means of

FIGURE 8

MAKE SCRIBE LINES ACROSS
FRONT EDGE OF FACTORY
FUEL CAM PLATE ONTO
BOTH SIDES OF PUMP BODY.

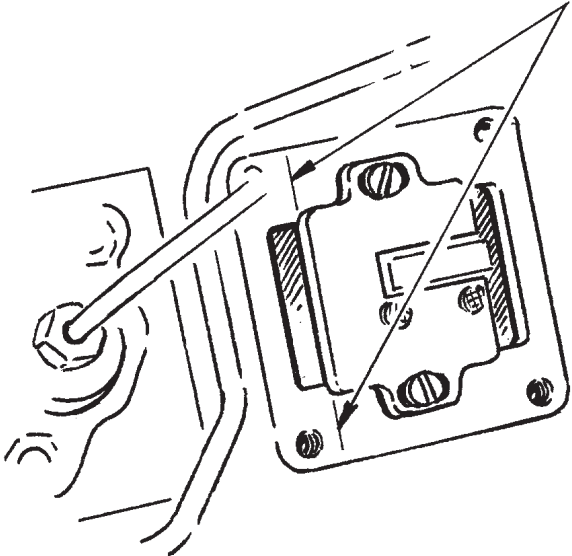

COVER SCREWS TEMPORARILY INSTALLED TO HOLD TEMPLATE.
ADD WASHERS UNDER SCREW HEADS IF SCREWS BOTTOM
OUT BEFORE CLAMPING TEMPLATE.

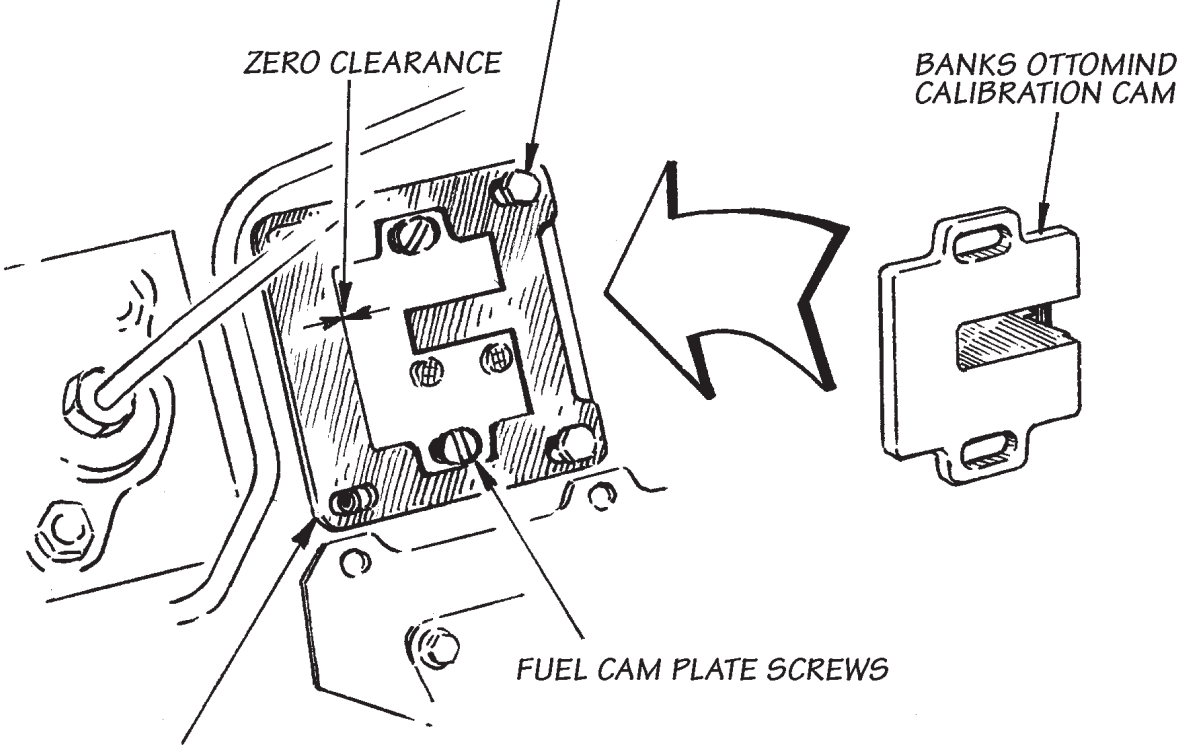

GUIDE TEMPLATE SHOWN INSTALLED
OVER FACTORY FUEL CAM PLATE

removal. A sharp chisel with an approximately $\frac{3}{8}$ " wide blade may be used to chisel a screwdriver "slot" across the screw head. Pass the chisel between the injector tubes and strike straight down to create a "V" notch, then use a $\frac{5}{16}$ - $\frac{3}{8}$ " blade screwdriver with moderate downforce to turn the screw. See **Figure 6**. An alternate method is to drive the chisel into the screw head using blows upon a hand held impact driver tool set in the "removal" position, such as a Snap-On No. PIT 160 or equivalent. Install a hex or 8-point socket on the driver that will fit over the shank on the chisel. Another method is to drive a No. T15 (or in some cases a No. T20) male TORX bit into the screw head using either a hammer or hand impact driver. A center punch may be required to provide a depression in the top of the screw. When using a hand impact driver, use light hammer taps to seat the TORX bit, and progressively harder blows to loosen the screw.

40. Once this screw has been removed, save the washers and discard the screw, then loosen and remove the remaining three screws and retain these for reassembly. Remove two fuel shutdown solenoid bolts and the hairpin style clip from the solenoid actuator rod. Remove the solenoid and set it aside. Loosen slightly one bolt at the rear of the injection pump that will allow the fuel shutdown solenoid and bracket to be swung outboard just enough to clear the edge of the cam plate cover so the cover can be removed from the pump. Now remove the cam plate cover and set it aside. (See **Figure 7**)

41. Note the position of the cam plate attached to the pump body by two screws. Mark a scribe line in the pump body at the forward edge of the cam plate where it contacts the pump body. See **Figure 8**. This mark can be used as a reference should the original cam plate need to be reinstalled.

42. Place the installation guide template provided over the stock fuel cam plate. This template will provide the position reference for the Banks OttoMind calibration cam. Note: The guide template will only fit one way. If it appears to be misaligned or does not seem to fit, flip the plate over and try again.

43. Using two of the cam cover screws previously removed, loosely attach the guide template to the fuel pump body. Slide the guide template toward the rear of the engine so that there is zero clearance between the front edge of the fuel cam plate and the guide template. Hand tighten the two screws so that the guide template DOES NOT move during the remainder of the Banks OttoMind installation.

44. Loosen and remove the two screws holding the fuel cam plate in place. Keep these for reuse. Remove the stock fuel cam plate. Keep this piece in a safe location in case it is needed for future work on your vehicle.

45. Install the Banks OttoMind fuel calibration cam in the same position as the stock fuel cam plate, with zero clearance between the front edge of the calibration cam and the guide template. Replace the two screws to retain the calibration cam and tighten. Remove the installation guide template and keep it with your stock fuel cam plate for future use.

46. Once the Banks OttoMind is installed, replace the cam plate cover on the pump, swing the fuel shutdown solenoid bracket into place and reinstall the fuel shutdown solenoid. Thread the two lower cover screws into the pump finger tight. Install one original screw in the upper rear bolt hole. Install the supplied phillips head screw in the upper forward bolt hole. This is a temporary use screw to be replaced by the new break-off screw, provided, when fuel calibration is complete.

47. Place the cover in its exact original position, as indicated by the scribe lines on the cover and pump body. Maintaining its position, tighten the cover bolts and rear fuel-shutdown bracket bolt that was previously loosened.

48. After engine performance has been checked, replace the temporary-use Phillips-head screw with the new break-off screw provided. **CAUTION: Failure to install the new break-off screw when fuel calibration and performance have been verified can invalidate your emissions warranty.**

49. Reconnect the rubber hose and plastic tube to the "tee" fitting on the air flow valve cover, tighten the hose clamp and tube nut.

For PowerPack installation, proceed to step 51.

NOTE: Before slipping any boost tubes and the corresponding hoses, into position, ensure that all connection ends are clean and free of any oil residue and contaminants. Clean compressor outlet and all connection points with a non-oil based solvent such as Acetone, Mineral Spirits, Denatured Alcohol or Lacquer Thinner. Read and follow the manufactures operation instruction for non-oil based solvent cleaner.

50. Remove the rags covering the intake manifold opening and boost tube, then reinstall the boost tube hose onto the inlet casting. Check that the boost tube hose is properly

engaged on the manifold adapter and the clamp is positioned properly on the hose, then tighten the clamp nut.

For Stinger installation, proceed to CHECKING ENGINE PERFORMANCE.

TWINRAM MANIFOLD INSTALLATION

51. Loosen the tube nuts at both ends of all six fuel injection lines. Remove the two bolts from the intake manifold cover that retain the fuel injection line clamp brackets. Remove the injection lines as an assembly. It is very important that no dirt or debris be introduced to the fuel system while the injector lines are removed. Place the plastic caps provided over each injector nozzle and each fitting on the injection pump. Set the injector lines aside in a clean place. Remove the remaining manifold cover bolts and remove the remaining manifold cover bolts and remove the manifold cover. Make note of various bolt lengths and their locations. Cover the cavity in the cylinder head with clean rags to keep foreign material out while working.

52. Clean any remaining gasket residue from the cast iron surface of the cylinder head. Take

care to keep the gasket material from entering the cylinder head cavity. Remove any rags placed in the head cavity at this time to allow for the installation of the TwinRam manifold components.

53. If your motorhome is equipped with an air compressor, the inlet air for the compressor may be drawn from the intake manifold. A fitting and a length of hose are provided for adaptation to accommodate the compressor feed. Install the air compressor feed fitting in the large threaded hole in the TwinRam base plate. If your engine does not take air from the intake manifold, install the pipe plug provided in the threaded hole. Place the new gasket provided over the bolt pattern in the cylinder head and place the base plate in position. Apply a drop of Loctite to the threads of four metric socket-head capscrews provided and install into the recessed holes in the base plate. See **Figure 9**. Install ten factory fasteners finger tight in the remaining positions. Note the location of two slightly longer factory fasteners for mounting the fuel filter bracket. Also note the location of the new injection line bracket provided.

Figure 9

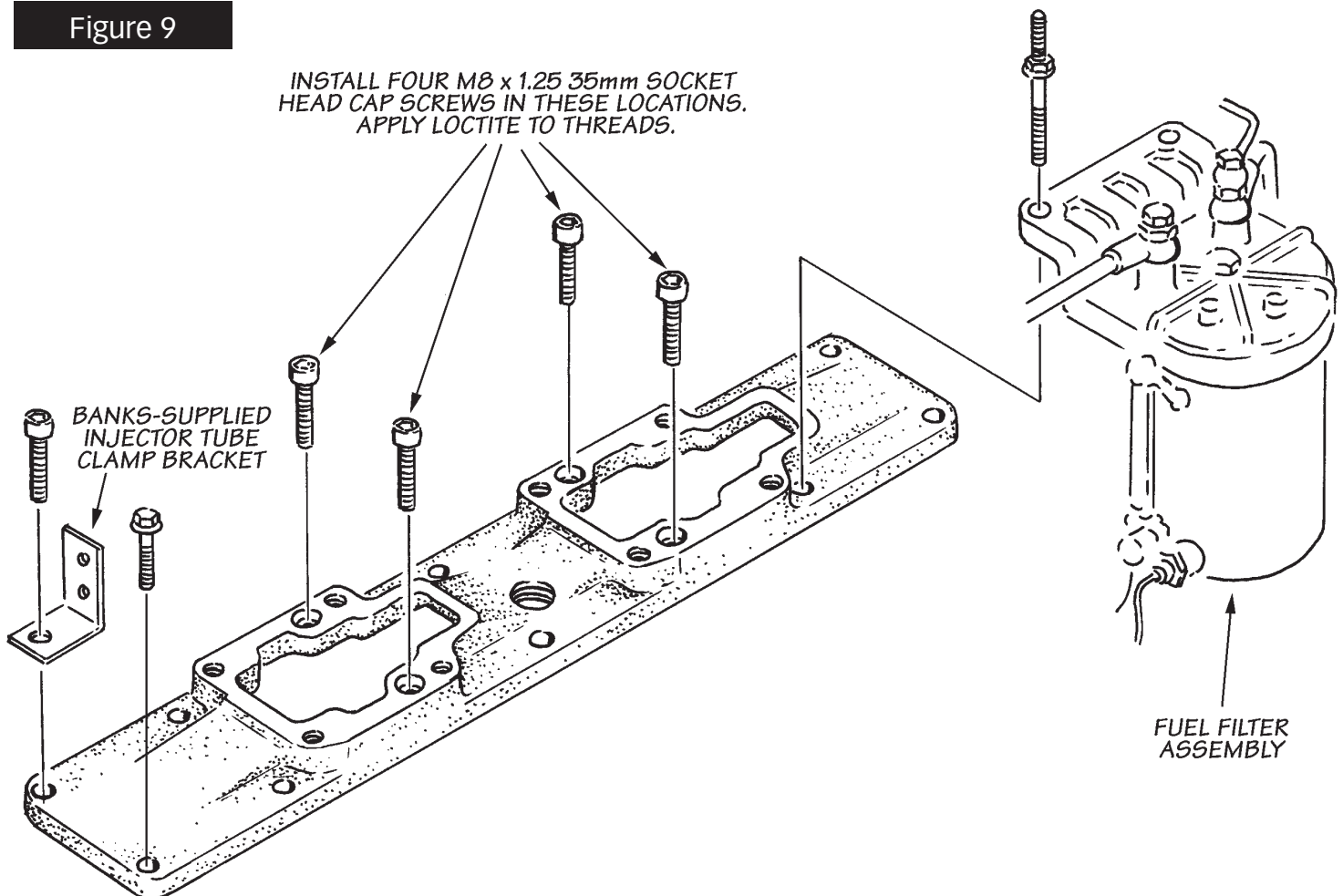
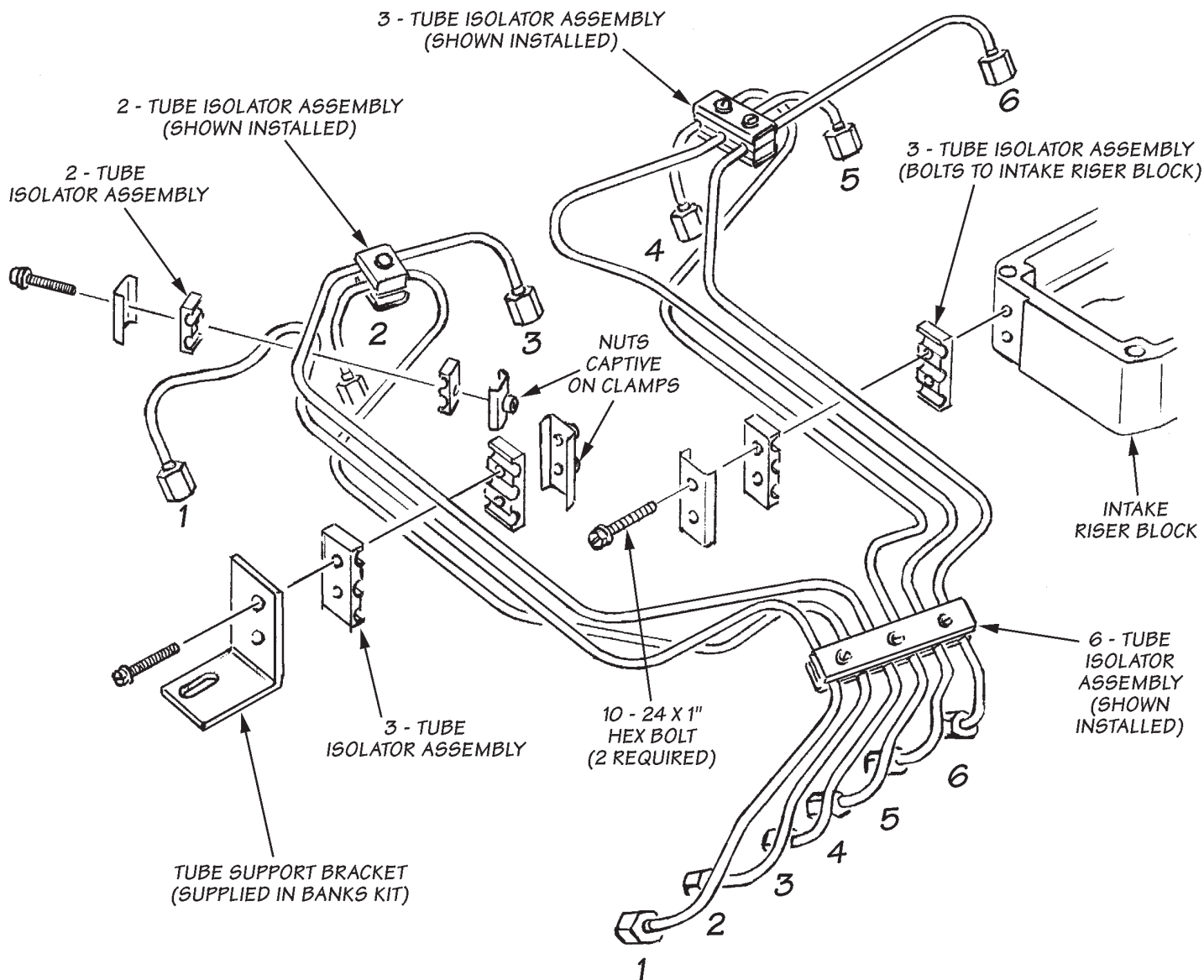

Figure 10



CPL 1553 – The factory injector lines will be reused. Remove the two line clamp assemblies from the injector feed lines that are bolted to brackets. Remove the plastic caps from the fuel pump and the injector nozzles. Reinstall the injector line assembly on the engine using the new bracket provided as shown in **Figure 9**. Do not tighten lines at this time. Torque all fourteen of the base plate bolts to 18 lb-ft. working from the center, outward.

CPL's 0987 and 1261 – The original factory injector lines must be replaced. Install each of the new lines in their proper location as shown in **Figure**

10. Install injector line separators as shown. The 6-tube separator is supplied. All others should be removed from the factory injection lines.

54. Set a heater housing gasket and the rear heater housing casting in place upon the manifold baseplate. Note that the gasket goes on one way to match the outline of the baseplate flange. Also note that the rear heater housing has a machined flat area and two threaded holes in the front surface of the housing. See **Figure 11**.

55. Set the other heater housing gasket and front heater housing in place on the baseplate.

FIGURE 11

(Refer to Bill of Materials list on pages 19-20 for parts.)

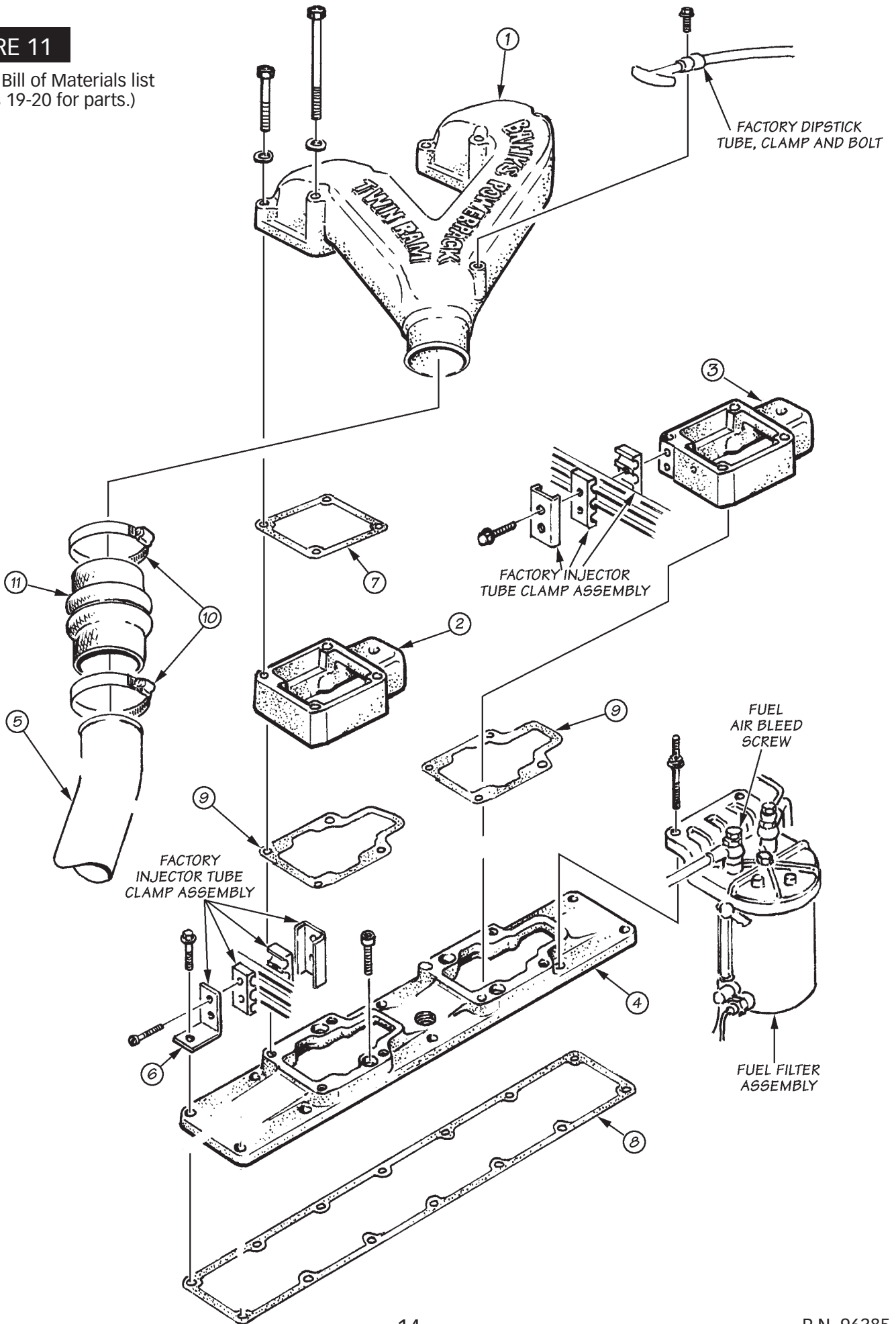
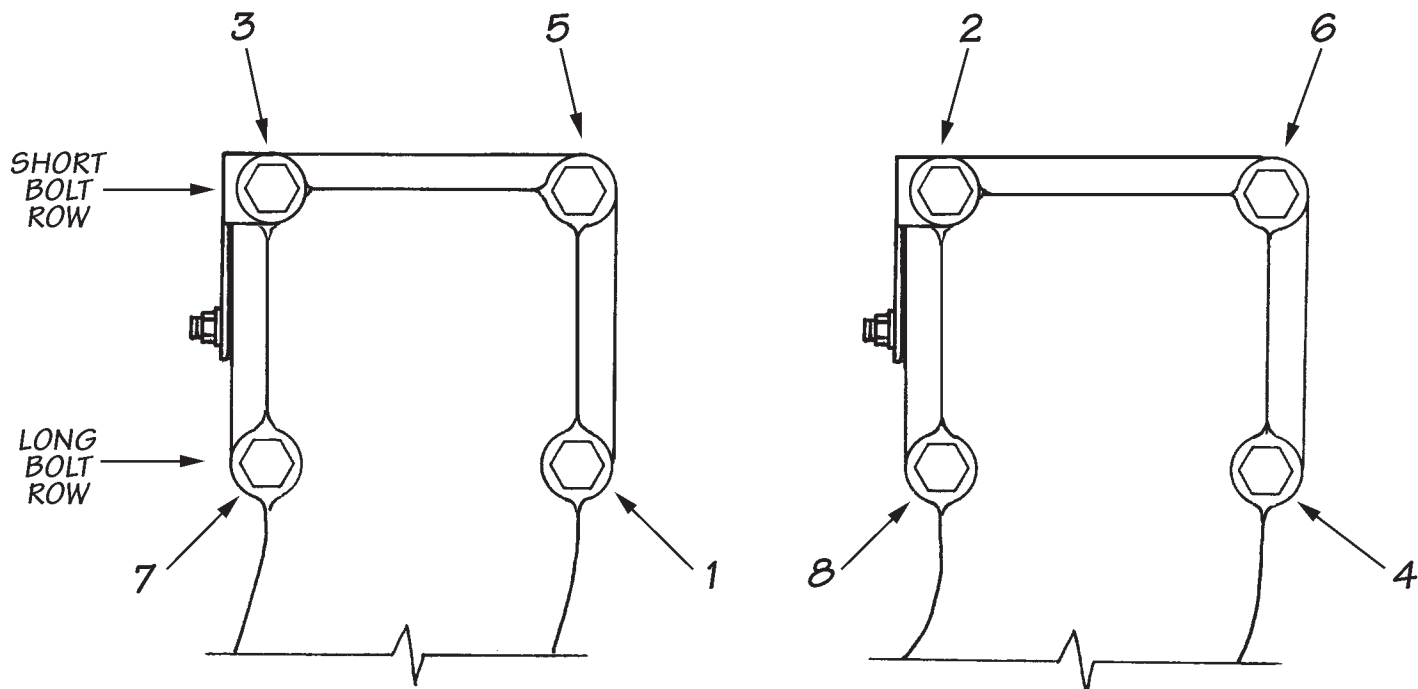

Figure 12

TWIN RAM MANIFOLD BOLT TORQUE SEQUENCE



It may be necessary to slightly bend one injector tube to clear the front corner of the forward heater housing. The injector tube must not contact the housing after assembly. Bend the tube as little as possible to obtain about $\frac{1}{16}$ -inch clearance to the housing. Use a smooth, rounded-edge pry tool to avoid nicking or gouging the tube.

56. Slip a $\frac{3}{8}$ washer on one of the $\frac{3}{8}$ x 5-inch hex bolts, then apply a drop of Loctite to the first few threads and slide the bolt into the rearmost long bolt hole on the Banks TwinRam manifold. Set an air inlet manifold gasket on top of each heater housing, then set the TwinRam manifold in place while guiding the bolt through the heater housing and gaskets. Use extreme care not to tear or damage the gaskets while installing the bolts as boost leaks can occur. Thread the bolt into the baseplate finger-tight, then install washers and apply Loctite to the remaining three 5-inch and four 3-inch $\frac{3}{8}$ hex bolts before threading them through the manifold, heater housings and gaskets. Torque bolts in the pattern shown in **Figure 12**. Tighten all eight bolts to 20 lb-ft., then in 5 lb-ft. increments to 35 lb-ft., each time using the pattern shown.

57. Once the bolts are torqued, slide one of the factory injector tube spacers between the rear heater housing and the three injector tubes, so that the spacer is positioned over the two threaded holes in the housing. Install the other

factory spacer half, and the factory clamp plate to the heater housing using two 10 - 24 x 1-inch bolts. When tightening the bolts, adjust the position of the clamp assembly to center the heater coil ground nut between the tubes. The tubes must not be allowed to vibrate against this nut. Once this position has been established, remove each bolt one at a time, apply Loctite and tighten.

58. Tighten all 12 injector tube nuts to 22 lb-ft. using a 19mm or $\frac{3}{4}$ -inch crow's-foot wrench on a torque wrench. Install factory injector tube clamp hardware onto the new bracket at the front of the baseplate and tighten.

59. Loosen the hose clamp at the intercooler end of the factory boost tube and remove the boost tube. Install the new boost tube provided. Rotate the tube such that the bend is aligned properly with the inlet to the TwinRam manifold and install with the hump hose provided. Retighten all the hose clamps. Bolt the dipstick tube and bracket to the top of the TwinRam manifold using the factory bolt.

FUEL LINE BLEEDING PROCEDURE

If injector lines have been disconnected, the engine may not start due to air in the lines or it may run erratically until air is purged. If the engine will not start after 30 seconds of cranking, allow a 2 minute starter cooling period, followed by another 30 seconds of cranking. If the engine will not start after several of these cycles, bleed the fuel system as follows:

A. Loosen the bleed bolt in the top of the forward banjo fitting above the fuel filter.

B. Operate the rubber push button primer on the fuel transfer pump until fuel exiting the bleed bolt is free of air. Tighten the bleed bolt to 6 lb-ft. of torque.

C. Crank the engine for 30 seconds followed by a 2 minute cooling period. Repeat this procedure several times as required to start engine.

D. Once engine starts, bring engine speed slightly above idle for 1-2 minutes to bleed additional air, then allow to idle.

If the engine still will not start or runs erratically after this procedure, bleed the high pressure lines while observing these safety precautions:

A. Place vehicle in park or neutral with parking brake set. Vehicle may start during purging procedure.

B. Do not bleed lines on a hot engine. Do not allow fuel to spray on a hot exhaust manifold.

C. High pressure fuel spray can puncture your skin. Wear goggles and protective clothing. Avoid contact with fuel spray while bleeding lines.

Bleed air from one high pressure injector line at a time as follows:

A. Slightly loosen the line nut at the injector end of the line.

B. Crank the engine until all air appears to be bled from the line. Do not crank for more than 30 seconds. Wait 2 minutes between cranking intervals.

C. Tighten each injector line nut to 22 lb-ft. of torque before moving to the next injector line.

NOTE: Engine may start and run while cranking to bleed air. Continue the air bleeding procedure on the remaining injector lines with the engine running, bleeding them one at a time until the engine runs smoothly.

CHECKING ENGINE PERFORMANCE

Go over the entire installation as a precautionary check to ensure that all clamps are tight, wiring and hoses are properly routed, and connections are tight. Start the engine and allow it to warm up. Drive the vehicle under light load (normal around town driving) for 20 to 30 minutes, and listen for any exhaust leaks or rattles, or intake boost leaks. Shut off the engine and re-tighten all intercooler and turbocharger boost clamps. These connections may have loosened with time, and if leaking, will cause a drop in boost pressure with a loss in performance. Check that clamps are properly positioned on hoses, and periodically check tightness of hose clamps at regular maintenance intervals, such as when the oil is changed.

Observe the operation of the boost and pyrometer gauges while driving under varying conditions. Turbocharger boost pressure will increase as a function of load and engine RPM, thus the engine will produce little boost while cruising at light throttle, with maximum boost while climbing hills heavily loaded during acceleration. Note the boost level seen during hard acceleration with a given load. If performance seems to have deteriorated sometime in the future, the maximum

boost figures may be compared to see if boost has dropped off. Lower boost may be caused by turbo ducting leaks, a malfunctioning wastegate or fuel injection pump, or a dirty air filter. Typical maximum boost pressure settings for the Dodge/Cummins diesel will vary considerably with stick or automatic transmission options, year model of vehicle and altitude.

Use your pyrometer (exhaust gas temperature) gauge to monitor exhaust gas temperature (EGT) in the engine. At idle, exhaust gas temperature will be very low, perhaps only 300 degrees F. As the engine is accelerated for higher speeds with greater loads, the EGT will rise. The highest EGT will be seen under maximum load at full throttle, such as climbing a steep grade with a heavily laden vehicle. Use caution if your pyrometer reading approaches 1300 F, with 1350 F being the ABSOLUTE MAXIMUM! Exceeding these figures for more than a brief moment may cause engine damage.

If the vehicle reaches maximum EGT under these conditions, downshift the vehicle to reduce load, or back off the throttle.

TROUBLE SHOOTING CHART

SYMPTOM	CAUSE	REMEDY
HIGH EGT	• EXCESSIVE FUEL DELIVERY	• CHANGE INJECTOR PUMP SETTING
	• FAULTY INJECTOR(S)	• REPAIR INJECTOR(S)
	• RESTRICTED EXHAUST SYSTEM	• CHECK FOR OBSTRUCTIONS
EXCESSIVE FUEL SMOKE (BLACK) POOR PERFORMANCE	• FAULTY INJECTOR(S)	• REPAIR INJECTOR(S)
	• DIRTY AIR CLEANER	• CLEAN OR REPLACE
	• RESTRICTED AIR INTAKE	• CHECK FOR BLOCKED OR COLLAPSED AIR INTAKE HOSES
EXCESSIVE OIL SMOKE (BLUE)	• POOR QUALITY or DIRTY DIESEL FUEL	• REPLACE FILTERS, CLEAN LINES, INJECTORS AND TANK AS REQUIRED
	• BLOCKED OR RESTRICTED TURBO OIL DRAIN	• ELIMINATE RESTRICTIONS IN THE DRAIN LINE
LACK OF BOOST, EXCESSIVE OIL SMOKE, & POOR PERFORMANCE	• DAMAGED TURBO BEARINGS, CAUSED BY DIRTY OIL OR LACK OF LUBRICATION	• REBUILD TURBO, CHECK OIL LEVEL, CHANGE OIL AND FILTER AT REGULAR SERVICE INTERVALS
	• WORN OR DAMAGED ENGINE COMPONENTS	• CHECK COMPRESSION, REPLACE RINGS OR VALVES
LOW BOOST, POOR PERFORMANCE, SOMETIMES WITH HIGH EGT	• RESTRICTED EXHAUST SYSTEM	• ELIMINATE RESTRICTIONS, CHECK FOR OBSTRUCTIONS
LACK OF BOOST OR LOW BOOST, POOR PERFORMANCE	• INTAKE SYSTEM LEAKS	• LOCATE AND SEAL LEAKS; CHECK INTAKE CLAMPS & MANIFOLD GASKETS
	• EXHAUST SYSTEM LEAKS AHEAD OF TURBOCHARGER EXHAUST INLET	• LISTEN FOR LEAKS, REPAIR AS NECESSARY
	• BROKEN TURBOCHARGER BLADES CAUSED BY FOREIGN OBJECTS ENTERING THE INTAKE OR EXHAUST SYSTEM	• REBUILD TURBOCHARGER; ELIMINATE MEANS OF FOREIGN OBJECT ENTRY
PYROMETER NOT WORKING	• CHECK FOR REVERSED WIRES	• REVERSE WIRES
	• POOR WIRE CONNECTIONS	• CLEAN AND SECURE CONNECTIONS. IF GAUGE READING CHANGES WHILE WIGGLING CONNECTIONS, CONNECTIONS ARE FAULTY.
	• WIRING CONNECTIONS SHORTED TOGETHER	• INSULATE CONNECTIONS
BOOST GAUGE NOT WORKING	• LOOSE, BROKEN, PINCHED, CUT, OR MELTED PLASTIC PRESSURE LINE	• REPAIR OR REPLACE AS REQUIRED, RE-ROUTE LINE AWAY FROM HAZARDS
	• NEEDLE IN GAUGE STICKS	• REPLACE GAUGE
GRADUAL LOSS OF PERFORMANCE, AND POSSIBLY BOOST ("FLATTENS OUT" AT HIGH RPM)	• CLOGGED, OR PARTIALLY CLOGGED, FUEL FILTER	• REPLACE FUEL FILTER(S)

IMPORTANT EMISSIONS INFORMATION

DIESEL SMOKE OPACITY TESTING

Several states are now imposing roadside inspections that test diesel vehicles for smoke opacity (density) and issue citations for excessively smokey vehicles. The predominate standard is a 40% maximum opacity limit, with vehicles exceeding this level either being fined or issued "fix-it" tickets. A 40% opacity level means that 40% of the light visible through the smoke as seen against a white background is blocked by the smoke. Thus a clear exhaust stream represents 0% opacity, while jet-black smoke represents 100% opacity.

The opacity test is conducted with one person depressing the accelerator pedal to the floor as quickly as possible with the engine out of gear while another person observes the opacity of the smoke. The engine is held at full throttle for approximately two seconds, then released. This is done 5-6 times, with the first 2-3 times being considered invalid, as built up carbon being blown out with the exhaust may show darker smoke. The initial burst of smoke from the next several accelerations is simultaneously compared with a tinted plastic sample while viewed against a white background under daylight conditions. This is referred to as a "snap idle" or "snap throttle" test and is often conducted at roadside inspection sites or truck weigh stations using a calibrated opacity meter placed over the smoke stream. Although comparison testing with the plastic sample will not give an actual opacity reading, and it can be interpreted differently because of light conditions and other variables, it will give you an approximate indication of whether the vehicle's smoke opacity is below the 40% level.

Included with this Banks Stinger system is a 4-inch square of acrylic plastic tinted to approximate a 40% opacity. By using this plastic in the following procedure, the vehicle's smoke opacity can be compared to the 40% test level.

1. Start the vehicle and allow the engine to warm up. You may want to drive the vehicle for 5-10 minutes to speed up the process. Park the vehicle outside so the tailpipe is not in shadow and the exhaust smoke can be viewed against a white background that is not in shadow. If a white background is not available, place a piece of white cardboard, at least one-foot square, so the exhaust smoke can be viewed in front of it.

2. With the vehicle running, set the transmission in Park or Neutral, and apply the parking brake. Have another person depress the accelerator pedal to the floor as quickly as possible and hold it there for 2-3 seconds, then release it. Repeat this procedure two more times.

3. Hold up the tinted plastic at arms length so it is directly above the path of the exhaust smoke, so both the smoke and the plastic can be viewed simultaneously against the white background while accelerating the vehicle. Have your helper repeat 2-3 more acceleration bursts while you observe the smoke and plastic sample.

Compare the tint of the initial puff of smoke during acceleration with the sample, after the initial puff the smoke will most likely be lighter. The darkest part of the acceleration burst is the level measured in the test. It may take several acceleration bursts for you to make a determination of the vehicle's opacity level.

4. If the smoke appears lighter than the sample, the opacity is less than 40%. If the smoke appears darker, the cam plate in the fuel injection pump may have been mispositioned during installation or the cam plate cover may have been reinstalled slightly out of position. Please refer to the OttoMind installation section of these instructions to verify that both the Banks OttoMind calibration cam and the cam plate cover are in the correct position. This test assumes that the injection pump and fuel injection system are adjusted properly and in good working order, as other factors may affect the opacity level.

NOTE: In no case should this test be considered as meeting any legal requirement where an actual opacity percentage number is required. It is a "ball-park" approximation to give the tuner a relative idea of where the vehicle's opacity level stands.

BILL OF MATERIALS

Cummins 5.9 Diesel Motorhome

FIG. #11	COMPONENT	49240 STINGER	42715 TWINRAM	42716 TWINRAM	42717 TWINRAM	49245 POWERPACK	49246 POWERPACK	49247 POWERPACK	49248 POWERPACK
	ASSEMBLY, Turbine Housing, 14cm p/n 24313✓		-	-	-	✓	✓	✓	✓
1	MANIFOLD, TwinRam p/n 42703	-	✓	✓	✓	✓	✓	✓	✓
2	HOUSING, Heater, Front p/n 42708	-	✓	✓	✓	✓	✓	✓	✓
3	HOUSING, Heater, Rear p/n 42707	-	✓	✓	✓	✓	✓	✓	✓
4	BASEPLATE, Manifold p/n 42706	-	✓	✓	✓	✓	✓	✓	✓
5	TUBE, Boost p/n 41114	-	✓	-	-	✓	-	✓	-
5	TUBE, Boost p/n 41117	-	-	-	✓	-	-	-	✓
5	TUBE, Boost p/n 41119	-	-	✓	-	-	✓	-	-
	ASSEMBLY, OttoMind p/n 62402	✓	-	-	-	-	-	-	-
	ASSEMBLY, OttoMind p/n 62407	-	-	-	-	-	✓	✓	✓
	ASSEMBLY, OttoMind p/n 62408	-	-	-	-	✓	-	-	-
	INJECTOR TUBE, #1 Cylinder p/n 43505	-	-	-	-	-	✓	✓	✓
	INJECTOR TUBE, #2 Cylinder p/n 43506	-	-	-	-	-	✓	✓	✓
	INJECTOR TUBE, #3 Cylinder p/n 43507	-	-	-	-	-	✓	✓	✓
	INJECTOR TUBE, #4 Cylinder p/n 43508	-	-	-	-	-	✓	✓	✓
	INJECTOR TUBE, #5 Cylinder p/n 43509	-	-	-	-	-	✓	✓	✓
	INJECTOR TUBE, #6 Cylinder p/n 43510	-	-	-	-	-	✓	✓	✓
	(2) BRACE, Short p/n 43515	-	-	-	-	-	✓	✓	✓
	(2) ISOLATOR p/n 43522	-	-	-	-	-	✓	✓	✓
	BRACE, Long, Lower p/n 43520	-	-	-	-	-	✓	✓	✓
	BRACE, Long, Upper p/n 43521	-	-	-	-	-	✓	✓	✓
6	BRACKET, Fuel Line p/n 43300	-	✓	✓	✓	✓	✓	✓	✓
	KIT, Boost Gauge p/n 64053	✓	-	-	-	✓	✓	✓	✓
	KIT, Pyrometer p/n 64007	✓	-	-	-	✓	✓	✓	✓
	(8) Washer, 3/8" p/n 91401	-	✓	✓	✓	✓	✓	✓	✓
	(4) Bolt, 3/8" 16 x 3" p/n 91435	-	✓	✓	✓	✓	✓	✓	✓
	(4) Bolt, 3/8" 16 x 5" p/n 91440	-	✓	✓	✓	✓	✓	✓	✓
	(4) Screw, M8-1.25 x 35mm p/n 91784	-	✓	✓	✓	✓	✓	✓	✓
	(2) Bolt, 10 24 x 1", Hex p/n 91829	-	✓	✓	✓	✓	✓	✓	✓
	(1) PLUG, 3/4" NPT p/n 92265	-	✓	✓	✓	✓	✓	✓	✓
	(1) FITTING, 3/4" MPT x 1" HSE p/n 92035	-	✓	✓	✓	✓	✓	✓	✓
7	(2) GASKET, Air Inlet Manifold p/n 93023	-	✓	✓	✓	✓	✓	✓	✓
8	GASKET, Baseplate p/n 93028	-	✓	✓	✓	✓	✓	✓	✓
9	(2) GASKET, Heater Housing p/n 93026	-	✓	✓	✓	✓	✓	✓	✓

Continued on page 20

BILL OF MATERIALS

Cummins 5.9 Diesel Motorhome

FIG. #11	COMPONENT	49240 STINGER	42715 TWINRAM	42716 TWINRAM	42717 TWINRAM	49245 POWERPACK	49246 POWERPACK	49247 POWERPACK	49248 POWERPACK
	GASKET, Oil Drain p/n 93042	✓	-	-	-	✓	✓	✓	✓
	GASKET, Turbo Inlet p/n 93027	✓	-	-	-	✓	✓	✓	✓
	GASKET, Outlet Adapter p/n 93029	✓	-	-	-	✓	✓	✓	✓
	(2) CLAMP, Hose #16 p/n 92816	-	✓	✓	✓	✓	✓	✓	✓
10	(2) CLAMP, T-Bolt p/n 92860	-	✓	✓	✓	✓	✓	✓	✓
11	HUMP HOSE p/n 94510	-	-	✓	✓	-	✓	-	✓
11	BOOST HOSE p/n 94288	-	✓	-	-	✓	-	✓	-
	HOSE, Heater, 1" x 3' p/n94464	-	✓	✓	✓	✓	✓	✓	✓
	PANEL, Mounting, 2 Gauge p/n 63002	✓	-	-	-	✓	✓	✓	✓
	(12) CAP, Plastic p/n 62041	-	✓	✓	✓	✓	✓	✓	✓
	LOCTITE, Adhesive p/n 90001	-	✓	✓	✓	✓	✓	✓	✓
	TAPE, Teflon p/n 91099	-	✓	✓	✓	✓	✓	✓	✓
(3)	PLAQUE, Banks Turbocharged p/n 96003	✓	-	-	-	-	-	-	-
(3)	PLAQUE, Banks Turbocharged p/n 96008	-	-	-	-	✓	✓	✓	✓
	(2) DECAL, Banks Power p/n 96004	-	✓	✓	✓	✓	✓	✓	✓
	OWNERS MANUAL p/n 96385	✓	✓	✓	✓	✓	✓	✓	✓
	CARD, Product Registration p/n 96392	✓	✓	✓	✓	✓	✓	✓	✓
	WARRANTY STATEMENT p/n 96362	-	✓	✓	✓	✓	✓	✓	✓
	WARRANTY STATEMENT p/n 96364	✓	-	-	-	-	-	-	-