

with Installation Instructions

Owner's Manual

Banks Monster® Exhaust System

2006 Chevy/GMC 6.0L 2500HD

THIS MANUAL IS FOR USE WITH MONSTER EXHAUST SYSTEMS 48340

Gale Banks Engineering
546 Duggan Avenue • Azusa, CA 91702
(626) 969-9600 • Fax (626) 334-1743

Product Information & Sales: (888) 836-6938
Customer Support: (888) 839-5600
Installation Support: (888) 839-2700

bankspower.com



General Installation Practices

If you have any questions concerning the installation of your Banks Monster Exhaust System, please call our Technical Service Hotline at (888) 839-2700 between 7:00 am and 5:00 pm (PT). If you have any questions relating to shipping or billing, please contact our Customer Service Department at (888) 839-5600.

Thank you.

1. Before starting work, familiarize yourself with the installation procedure by reading all of the instructions.
2. The exploded view (**Figure 1**) provides only general guidance. Refer to each step and section diagram in this manual for proper instruction.
3. Throughout this manual, the left side of the vehicle refers to the driver's side, and the right side to the passenger's side.
4. Disconnect the negative (ground) cable from the battery (or batteries, if there are two) before beginning work.

Tools Required:

- 1/2" and 3/8" drive ratchets with standard and metric sockets and 1/2" and 3/8" drive extension
- Standard and metric combination or open-end wrenches
- Standard screwdriver
- Clean shop towels or rags
- Pry-bar
- Reciprocating saw

5. Route and tie wires and hoses a minimum of 6" away from exhaust heat, moving parts and sharp edges. Clearance of 8" or more is recommended where possible.

6. When raising the vehicle, support it on properly weight-rated safety stands, ramps or a commercial hoist. Follow the manufacturer's safety precautions. Take care to balance the vehicle to prevent it from slipping or falling. When using ramps, be sure the front wheels are centered squarely on the topsides. When raising the front of the vehicle, put the transmission in park, set the parking brake, and block the rear wheels. When raising the back of the vehicle, be sure the vehicle is on level ground and the front wheels are blocked securely. **Caution! Do not use floor jacks to support the vehicle while working under it. Do not raise the vehicle onto concrete blocks, masonry or any other item not intended specifically for this use.**

7. During installation, keep the work area clean. Do not allow anything to be dropped into intake, exhaust, or lubrication system components while performing the installation, as foreign objects will cause immediate engine damage upon start-up.

Highly recommended tools and supplies:

- Foot-pound torque wrench
- Penetrating oil or light lubricant spray

Products Available from Banks Power for the 2006 Chevy/GMC 6.0L 2500HD



Banks iQ System (P/N 61201)

- 5" touchscreen interface
- Interchangeable gauge display, read and clear codes, monitor engine diagnostics, log data, time your vehicles runs and much more.

Torque Tubes (P/N 48011)

- Virtually indestructible
- Each Torque Tube has a seamless high-velocity collector.
- Literally "pulls" out the exhaust, unleashing greater torque and helping the intake stroke to draw in more air.

Banks Ram-Air Intake System (P/N 41800-41802)

- Increases your airflow over stock.
- Adds power, improves fuel economy, lowers EGTs and reduces smoke.

Banks AutoMind Programmer (P/N 66104)

- Clear and view OBDII Diagnostic Trouble Codes (DTC).
- Loaded with dyno-proven tuning files
- Speed Limiter adjustment capabilities
- Recalibration of the speedometer
- Customize and adjust gearing, tire size and fuel octane

For More Information please call (888) 635-4565
or Visit us online @ www.bankspower.com

General Assembly

Figure 1

| Item # | Description | P/N | Qty. |
|--------|---------------------------|-------|------|
| 1 | Y-pipe, CCSB | 53636 | 1 |
| 2 | Monster Muffler | 54008 | 1 |
| 3 | Rear Muffler Hanger Clamp | 53637 | 1 |
| 4 | Tailpipe, Front | 53626 | 1 |
| 5 | Tailpipe, Rear | 53627 | 1 |
| 6 | Clamp, 3", Saddle | 52465 | 2 |
| 7 | Clamp, 3.5", Saddle | 52468 | 2 |
| 8 | Banks Decals | 96009 | 2 |

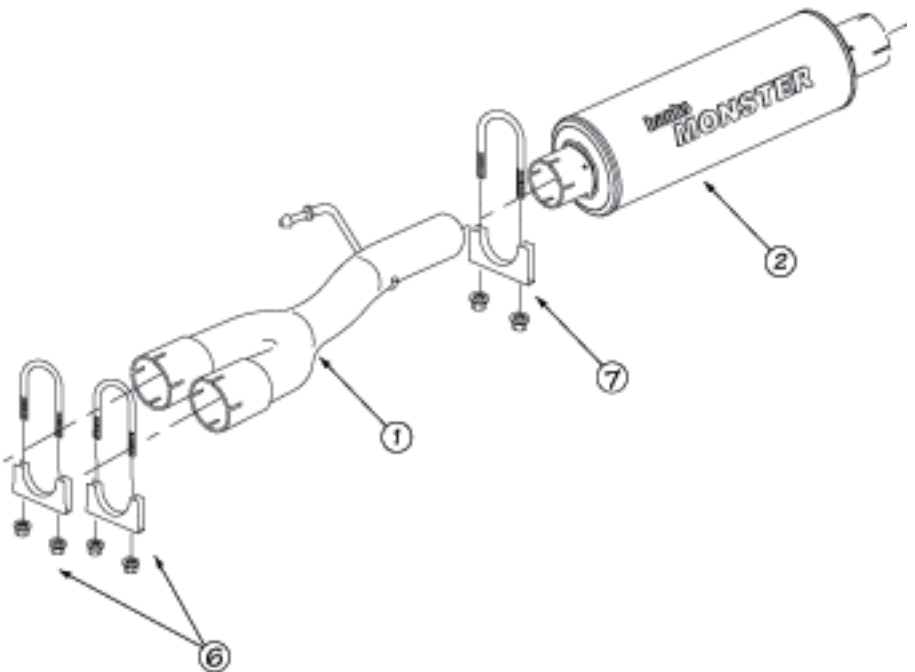

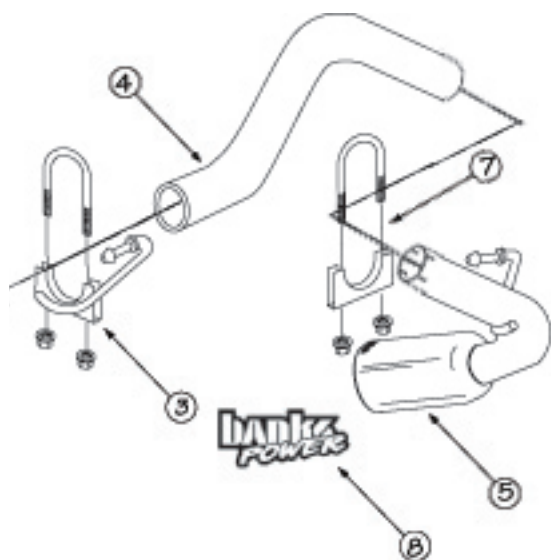

Monster Exhaust System Installation

1. Disconnect the negative (ground) cable from the battery (if there is more than one battery, disconnect both negative cables). Secure the cable so it cannot accidentally come in contact with the post.

2. Raise the vehicle and support it securely with properly weight-rated safety stands, ramps or a commercial hoist. Take care to balance the vehicle to prevent it from slipping or falling. When using ramps, be sure the wheels are centered squarely on the topsides. Place the transmission in park (automatic), set the parking brake and securely block the wheels that are on the ground.

CAUTION: DO NOT WORK UNDER ANY VEHICLE SUPPORTED ONLY BY A JACK. SEVERE INJURY MAY RESULT.

3. Using a reciprocating saw, cut the two (2) intermediate pipes 13" front of the muffler weld. Take time when measuring and cutting the factory intermediate pipes to ensure the proper location and a straight cut. Improper cut will result in poor fitment of the Banks Monster exhaust system (see **Figure 2**).

4. Remove the rear muffler hanger pin and tailpipe hanger pin from the vehicle's rubber hanger. Remove the tailpipe, muffler and intermediate pipe assembly from the vehicle.

NOTE: Spray lubricant may assist in hanger pin removal. Rubber hangers can also be removed from the vehicle to assist in tailpipe / muffler removal.

5. Install a three-inch (3") clamp on each previously cut factory intermediate pipe outlets. Install the Banks y-pipe onto the two (2) previously cut pipe outlets. Be sure the

y-pipe jog is orientated with the jog going up towards the cab. Install the y-pipe hanger into the vehicle's rubber hanger. Lightly tighten the two (2) three-inch clamps on the y-pipe inlet. (see **Figure 3**).

NOTE: All clamps should be positioned at the beginning of the slots (on the 1/2 circle punch).

NOTE: Once the pipe / muffler has been completely engaged in the slip joint, mark the pipe with a scribe or tape for reference when tightening the clamps later in the installation. Mark each slip joint in this fashion.

6. Install a 3-1/2" clamp onto the y-pipe outlet.

7. Install the Monster Muffler inlet (Note the inlet labeling of the muffler) onto the y-pipe outlet. Orient the Monster logo such that is visible from the passenger side and parallel with the frame rail. Align the clamp onto the muffler inlet (see **Figure 3**).

8. Install the rear muffler hanger clamp onto the Monster Muffler outlet. Insert the hanger pin to into the vehicles rubber hanger (see **Figure 4**).

9. From the vehicle rear, route the front tailpipe over the rear end. Install the front tailpipe into the Banks Muffler outlet. Lightly tighten the rear muffler hanger clamp to secure the front tailpipe. Install the 3.5" exhaust clamp onto the outlet of the front tailpipe. Install the rear tailpipe into the front tailpipe. Start the rear tailpipe hanger pin into the corresponding vehicle rubber hanger. Lightly tighten the 3.5" exhaust clamp to secure the front tailpipe to the rear tailpipe.

10. Adjust the tip about 1/2" under the body panel, such that the tip position is aesthetically pleasing.

Figure 2

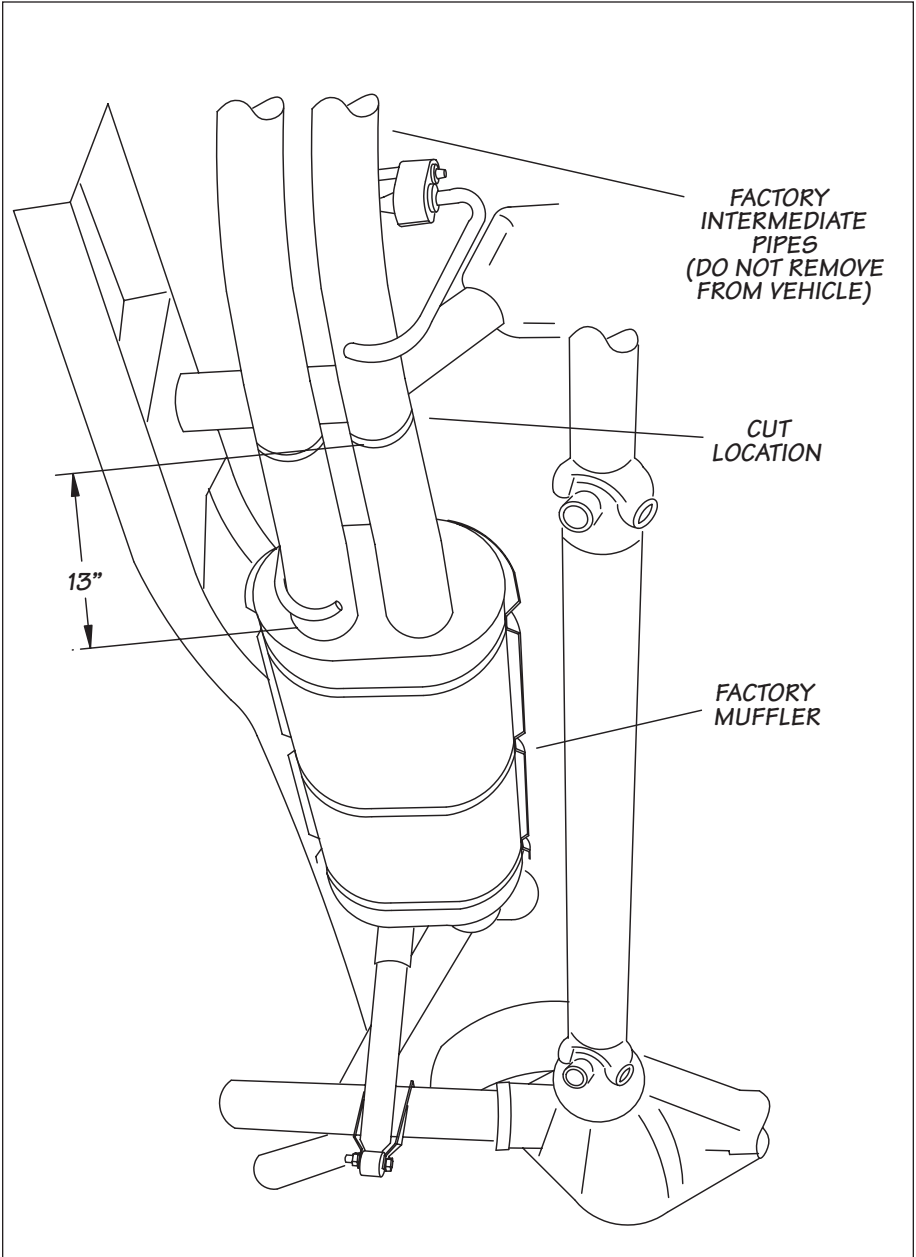
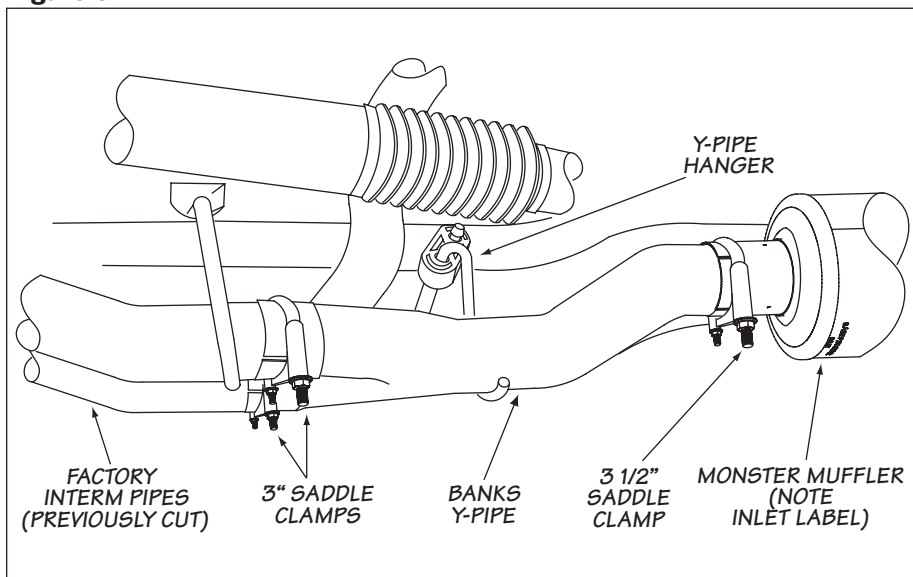

Figure 3



11. Adjust each of the pipes to ensure that all of the hanger pins are parallel with the frame mounted pins and that the rubber hangers are all positioned slightly forward (See **Figure 5**). This allows the hangers to be properly positioned once the exhaust reaches operating temperature.

12. With the exhaust positioned properly, begin to evenly tighten the clamps starting with the ones closest to the front of the vehicle and working your way back. Torque the exhaust clamps evenly to 35 ft-lbs. Make sure that each slip is fully inserted (+/-1/4").

13. Remove the protective covering from the tailpipe tip.

CAUTION: the protective covering may ignite and burn if not removed prior to running the engine.

14. Your system includes two (2) Banks Power logos designed to complement the vehicle's "2500 HD" emblems on passenger and driver side doors. The BanksPower decal can be placed 1/4" above the emblems.

15. Re-connect the negative battery cable. Start the engine and listen for exhaust leaks. Tighten the exhaust clamps as necessary. Whenever possible, tack weld slip connections to prevent disengagement is recommended.

16. The Banks Monster Exhaust installation is now complete.

Figure 4

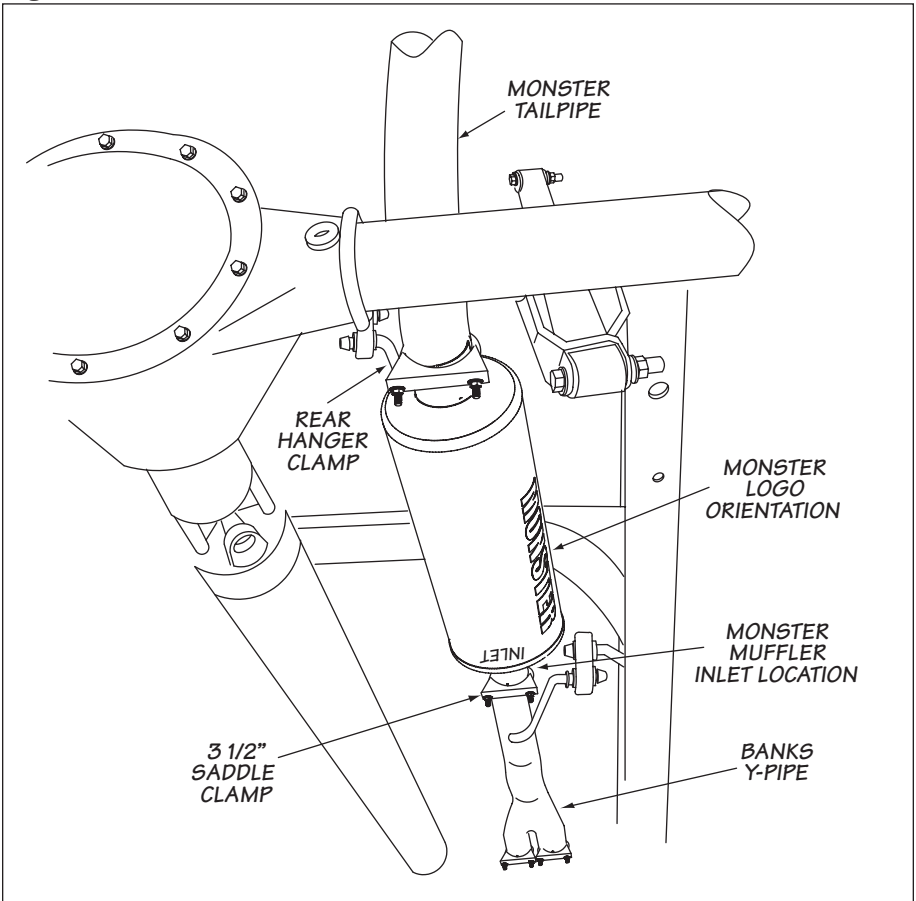
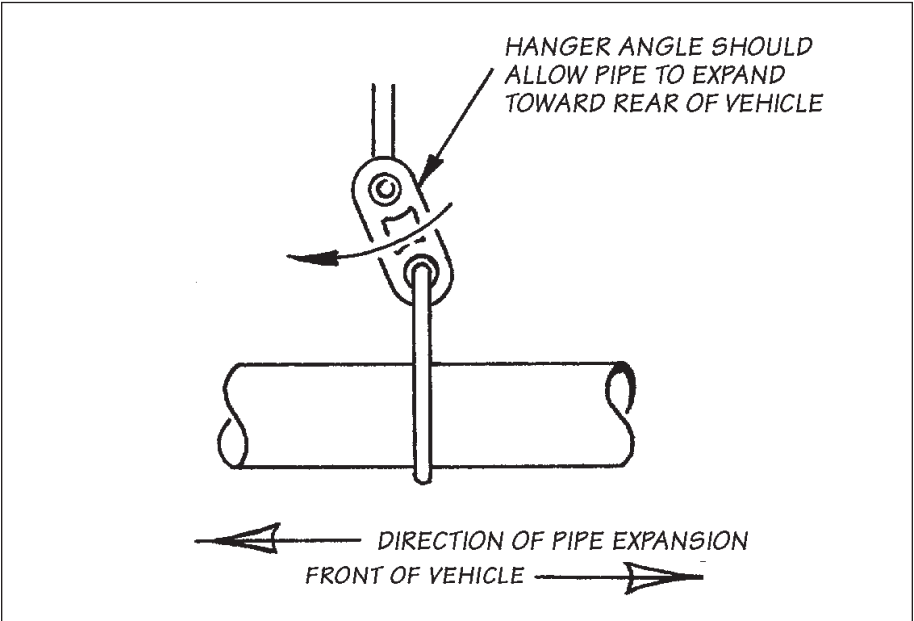

Figure 5



Notes

Gale Banks Engineering
546 Duggan Avenue • Azusa, CA 91702
(626) 969-9600 • Fax (626) 334-1743

Product Information & Sales: (888) 635-4565
Customer Support: (888) 839-5600
Installation Support: (888) 839-2700

bankspower.com