

Owner's Manual with Installation Instructions

Banks Monster[®] Exhaust System

**2011-2014 Ford
F-150 5.0L & 6.2L V8 SuperCrew Short/Long bed,
SuperCab Short bed &
F-150 3.5L ECO Boost SuperCrew Short bed**

THIS MANUAL IS FOR USE WITH SYSTEMS 48761

Gale Banks Engineering
546 Duggan Avenue • Azusa, CA 91702
(626) 969-9600 • Fax (626) 334-1743

Product Information & Sales: (888) 635-4565
Customer Support: (888) 839-5600
Installation Support: (888) 839-2700
bankspower.com

General Installation Practices

Dear Customer,

If you have any questions concerning the installation of your Banks Power System, please call our Technical Service Hotline at (888) 839-2700 between 7:00 am and 4:00 pm (PT). If you have any questions relating to shipping or billing, please contact our Customer Service Department at (888) 839-5600.

Thank you.

1. Before starting work, familiarize yourself with the installation procedure by reading all of the instructions.
2. The exploded view (**Figure 1**) provides only general guidance. Refer to each step and section diagram in this manual for proper instruction.
3. Throughout this manual, the left side of the vehicle refers to the driver's side, and the right side to the passenger's side.
4. Disconnect the negative (ground) cable from the battery (or batteries, if there are two) before beginning work.
5. Route and tie wires and hoses a minimum of 6" away from exhaust heat, moving parts and sharp edges. Clearance of 8" or more is recommended where possible.
6. When raising the vehicle, support it on properly weight-rated safety stands, ramps or a commercial hoist. Follow the manufacturer's safety precautions. Take care to balance the vehicle to prevent it from slipping or falling. When using ramps, be sure the front wheels are centered squarely on the topsides. When raising the front of the vehicle, put the transmission in park, set the parking brake, and block the rear wheels. When raising the back

of the vehicle, be sure the vehicle is on level ground and the front wheels are blocked securely.

CAUTION! Do not use floor jacks to support the vehicle while working under it. Do not raise the vehicle onto concrete blocks, masonry or any other item not intended specifically for this use.

7. During installation, keep the work area clean. Do not allow anything to be dropped into intake, exhaust, or lubrication system components while performing the installation, as foreign objects will cause immediate engine damage upon start-up.

Tools Required:

- 1/2" and 3/8" drive ratchets with standard and metric sockets and 1/2" and 3/8" drive extension
- Standard and metric combination or open-end wrenches
- Standard screwdriver
- Clean shop towels or rags
- Pry-bar

Highly recommended tools and supplies:

- Foot-pound torque wrench
- Penetrating oil or light lubricant spray

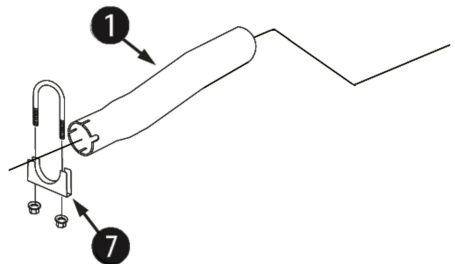

General Assembly

Figure 1

Item	Description	Part#	Qty
1	Intermediate Pipe	53380	1
3	Muffler	53962	1
4	Front Tailpipe	53394	1
5	Rear Tailpipe	53395	1
6	Monster Tip	52718	1
7	Clamp, 2.5"	52461	1
8	Hanger Clamp, 3"	53389	1
9*	Clamp, 3"	52465	1
10**	Clamp, 3.5"	52468	1
11	Band Clamp, 3.5"	52467	1
12	Banks Urocals	96009	2

* For Ford 3.5L ECO Boost models receive two (2) 3" Clamps

** Ford 3.5L ECO Boost model kit do not use 3.5" Clamps

Note: Item #2 is not used in this install and is intentionally removed from this guide

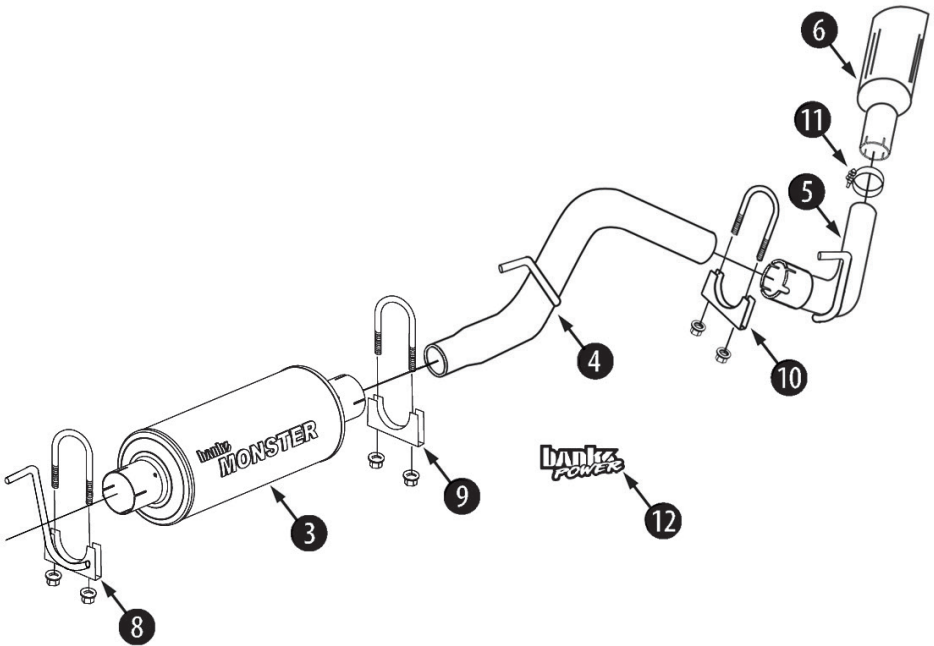

Monster Exhaust System Installation

1. Disconnect the negative (ground) cable from the battery (if there is more than one battery, disconnect both negative cables). Secure the cable so it cannot accidentally come in contact with the post.

2. Raise the vehicle and support it securely with properly weight-rated safety stands, ramps or a commercial hoist. Take care to balance the vehicle to prevent it from slipping or falling. When using ramps, be sure the wheels are centered squarely on the topsides. Place the transmission in park (automatic), set the parking brake and securely block the wheels that are on the ground.

CAUTION: DO NOT WORK UNDER ANY VEHICLE SUPPORTED ONLY BY A JACK. SEVERE INJURY MAY RESULT.

3. From under the vehicle remove the factory exhaust starting at the rear of the muffler. Remove the tailpipe by removing and retaining the two (2) M8x1.25 bolts

supporting the rear tailpipe hanger. Remove and retain the rear rubber hanger from the tailpipe (see **Figure 2**).

4. Loosen the factory band clamp at the front of the muffler. Using spray lubricant, lube the front and rear muffler hanger pins. Remove the muffler and tailpipe assembly from the vehicle (see **Figure 3**).

NOTE: Removing the rubber hangers from the vehicle may assist in exhaust removal.

5. Install the supplied 2 1/2" exhaust clamp onto the outlet of the factory intermediate pipe.

Install Banks intermediate pipe into the factory intermediate pipe outlet. Lightly tighten the clamp (see **Figure 4**).

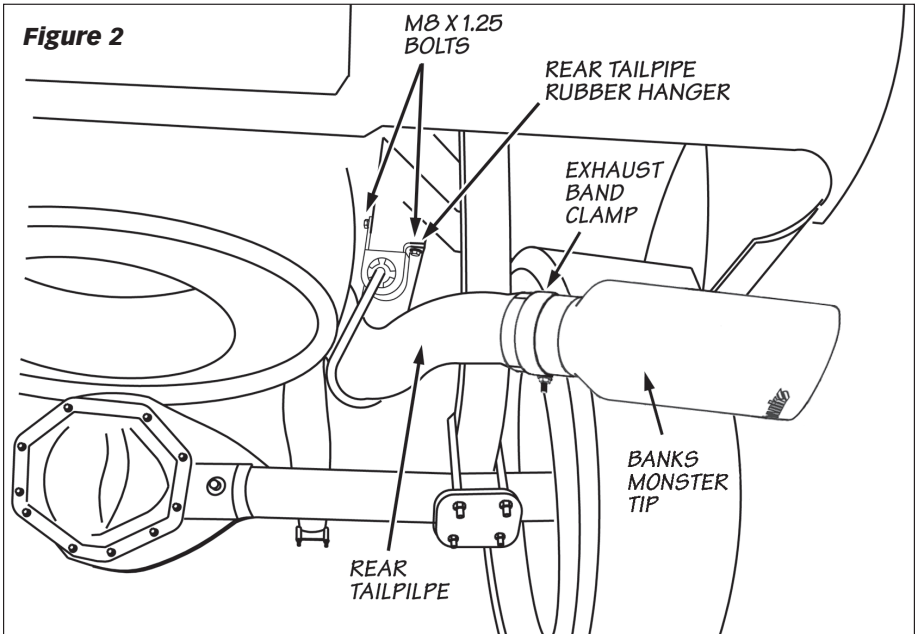

Figure 3

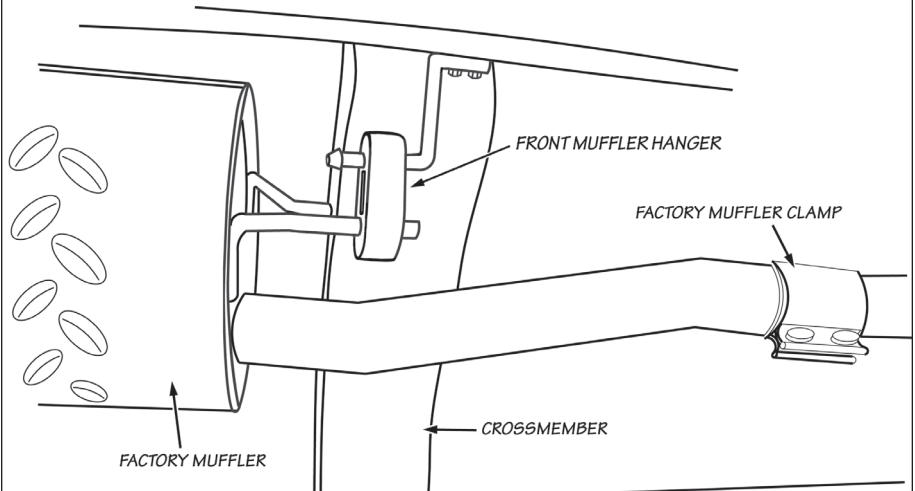
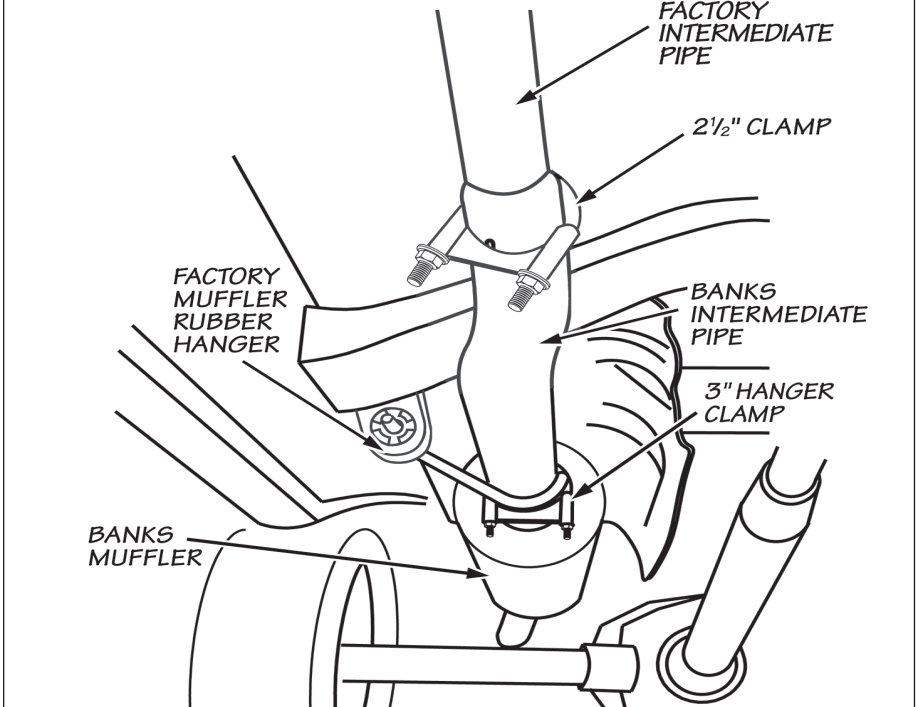

Figure 4 Ford F-150 Crew Cab model shown



6. (This Step Has been Removed)

7. Install the 3" hanger clamp onto the muffler inlet. The Hanger pin should face the front of the vehicle. Install Banks Muffler inlet (**Note the inlet labeling of the muffler**) onto the intermediate pipe and lightly tighten the 3" hanger clamp.

8. Install a 3" clamp on the Banks Muffler outlet. From the vehicle rear, route the Front Tailpipe over the rear axle. Start the Front Tailpipe hanger pin into the corresponding vehicle rubber hanger. Install the Front Tailpipe into the Banks Muffler Outlet (see **Figure 6**).

6. Loosely tighten the 3" clamp to secure the Front Tailpipe.

NOTE: Install the rubber hanger pins to the vehicle frame if previously removed.

9. For Ford 2011 3.5L ECO Boost, install a 3" clamp onto the outlet of the front tailpipe.

For all other models, Install a 3.5" clamp onto the outlet of the Front Tailpipe. Install the Rear Tailpipe into the Front Tailpipe outlet. Install the rear factory rubber hanger onto the rear tailpipe hanger pin. Loosely tighten the clamp to secure the Rear Tailpipe. Reinstall the two (2) factory M8x1.25 bolts through the rubber hanger into the vehicle frame. See **Figure 2**.

10. Install the band clamp over the inlet of the Monster tip. Install the Monster tip and band clamp onto the rear tailpipe. Loosely tighten the band clamp to secure the Monster tip. See **Figure 2**.

11. Adjust the tip about 1/2"-1" under the body panel, such that the position is aesthetically pleasing.

Figure 6

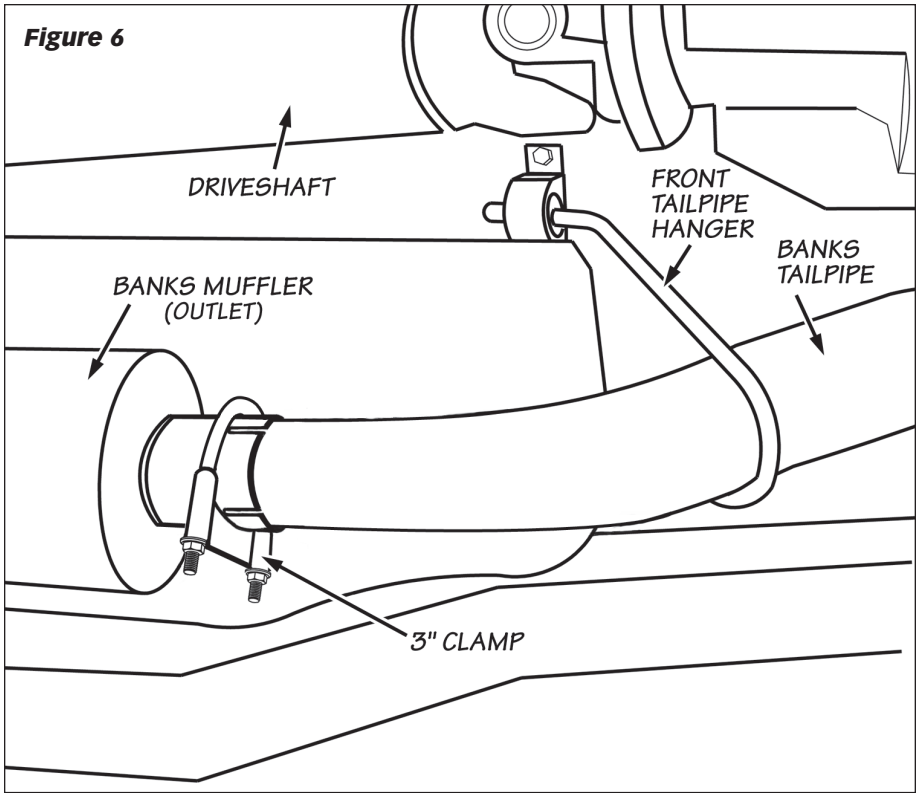

12. With the exhaust positioned properly, begin to tighten the clamps and hardware starting with the ones closest to the front of the vehicle and working your way back. Torque the exhaust clamps evenly to 35 ft-lbs. Make sure that each slip is fully inserted (+/- 1/4"). Torque the factory M8 hardware to 22 ft-lbs.

13. Remove the protective covering from the tailpipe tip.

CAUTION: The protective covering may ignite and burn if not removed prior to running the engine.

14. Your system includes two (2) "Banks Power" logos designed to complement the Ford emblems on the vehicles front fenders. Use the provided measurements for a clean factory look (see **Figure 7**).

15. Re-connect the negative battery cable. Start the engine and listen for exhaust leaks. Tighten the exhaust clamps as necessary. Whenever possible, tack weld slip connections to prevent disengagement is recommended. The Banks Monster Exhaust installation is now complete.

Figure 7

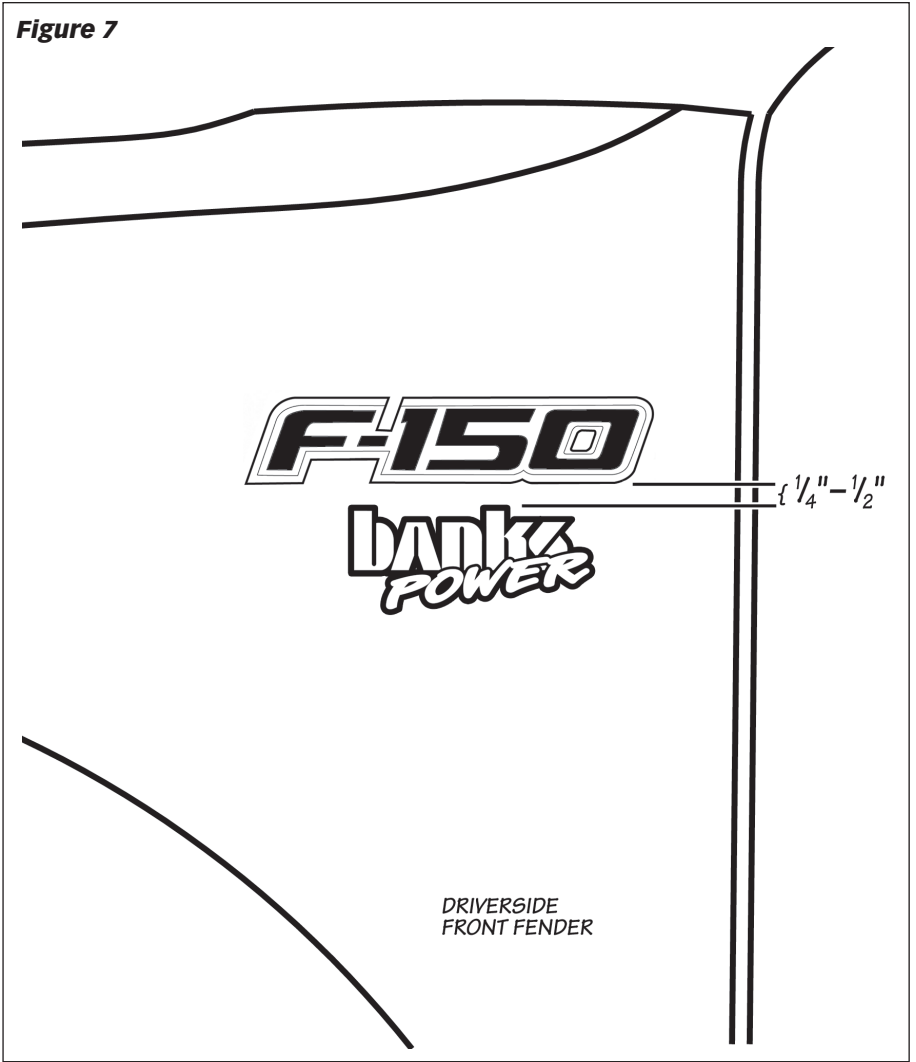

Gale Banks Engineering
546 Duggan Avenue • Azusa, CA 91702
(626) 969-9600 • Fax (626) 334-1743

Product Information & Sales: (888) 635-4565
Customer Support: (888) 839-5600
Installation Support: (888) 839-2700

bankpower.com